



Raymarine®

EV-1

Installation Instructions

Document number: 87472 (Rev 2) | English (en-US) | Date: 12-2025

Legal notices

Trademark and patents notice

Raymarine®, **Tacktick®**, **Pathfinder®**, **Clear Pulse®**, **Truzoom®**, **SeaTalk®**, **SeaTalk HS™**, **SeaTalk NG™**, and **MicroNet™**, are registered or claimed trademarks of Raymarine UK Ltd.

FLIR®, **Fishidy®**, **Fishing Hot Spots®**, **YachtSense™**, **DockSense®**, **RangeFusion™**, **DownVision®**, **SideVision®**, **RealVision®**, **HyperVision™**, **Wi-Fish®**, **Dragonfly®**, **Element®**, **Quantum®**, **Cyclone™**, **Alpha™**, **Axiom®**, **Infrared Everywhere**, **The World's Sixth Sense** and **ClearCruise®** are registered or claimed trademarks of Teledyne FLIR LLC.

All other trademarks, trade names, or company names referenced herein are used for identification only and are the property of their respective owners.

This product is protected by patents, design patents, patents pending, or design patents pending.

Fair Use Statement

You may print no more than three copies of this manual for your own use. You may not make any further copies or distribute or use the manual in any other way including without limitation exploiting the manual commercially or giving or selling copies to third parties.

Content notice

Please ensure that you have obtained this document only from Raymarine, and that it is the **latest** available version.

There are numerous third-party Internet websites (such as *www.manualslib.com*) hosting Raymarine product manuals. These websites are not authorized by Raymarine to do so, and are often hosting illegitimate or older versions of Raymarine product manuals, which may contain inaccurate or misleading information.

To obtain the latest official documentation for a Raymarine product, please visit the official Raymarine website: www.docs.raymarine.com

Artificial Intelligence (AI) content notice

There are numerous third-party **Artificial Intelligence (AI)** services available to the public, which are capable of providing a summary or transcription of the information provided by official Raymarine publications or websites, either in written or audio/video formats. These services may alter, supplement, or convey the original information provided by Raymarine in inaccurate or misleading ways.

Please ensure that you have obtained this document only from Raymarine, and that it is the **latest** available version.

CONTENTS

CHAPTER 1 IMPORTANT INFORMATION	8		
Safety warnings.....	8		
Product warnings.....	8		
Regulatory notices.....	9		
Disclaimer.....	9		
Water ingress.....	9		
Suppression ferrites.....	9		
Connections to other equipment.....	10		
Declaration of Conformity.....	10		
PSTI Compliance.....	10		
Product disposal.....	10		
Warranty policy and registration.....	10		
IMO and SOLAS.....	10		
Technical accuracy.....	10		
Publication copyright.....	10		
CHAPTER 2 DOCUMENT INFORMATION	11		
2.1 Applicable products.....	12		
2.2 Product documentation.....	12		
Applicable documentation.....	12		
Related documentation.....	12		
2.3 Document illustrations.....	12		
2.4 Applicable software version.....	12		
2.5 New software improvements.....	12		
CHAPTER 3 PRODUCT AND SYSTEM OVERVIEW	14		
3.1 Product overview.....	15		
3.2 SeaTalk NG.....	15		
3.3 Multiple data sources (MDS).....	15		
Multiple data source exceptions.....	16		
3.4 Required additional components.....	16		
3.5 Evolution-Series minimum system example (ACU-100 / ACU-150).....	17		
3.6 Evolution-Series minimum system example (ACU-200 / ACU-400).....	17		
3.7 Evolution-Series recommended system example (ACU-100 / ACU-150).....	18		
3.8 Evolution-Series recommended system example (ACU-200 / ACU-300 / ACU-400).....	19		
3.9 Software updates.....	20		
CHAPTER 4 COMPATIBLE AUTOPILOT CONTROLLERS	21		
4.1 Compatible autopilot controllers.....	22		
4.2 Compatible SeaTalk NG autopilot controllers.....	22		
4.3 Compatible SeaTalk 1 autopilot controllers.....	23		
4.4 Compatible MFD / chartplotter autopilot controllers.....	24		
CHAPTER 5 PARTS SUPPLIED	25		
5.1 Parts supplied.....	26		
CHAPTER 6 PRODUCT DIMENSIONS	27		
6.1 Product dimensions.....	28		
CHAPTER 7 LOCATION REQUIREMENTS	29		
7.1 Warnings and cautions.....	30		
7.2 Location requirements.....	30		
7.3 Compass safe distance.....	31		
7.4 EMC installation guidelines.....	31		

Electromagnetic interference safe distance	31	11.1 SeaTalk NG pilot controller connection.....	48
		11.2 SeaTalk 1 pilot controller connection.....	48
CHAPTER 8 MOUNTING.....	33	CHAPTER 12 POWER CONNECTIONS.....	49
8.1 Tools required for installation	34	12.1 SeaTalk NG power supply	50
8.2 Fixing screw suitability	34	12.2 Power connection via Autopilot Control Unit (ACU-Series).....	50
8.3 Surface mounting	34	12.3 Inline fuse requirement.....	50
8.4 Surface mounting using the riser.....	35	12.4 Inline fuse and thermal breaker ratings	51
8.5 Bracket mounting.....	36	12.5 12 Volt dc only	51
8.6 Releasing the product from the bracket	38	12.6 SeaTalk NG power cables	51
CHAPTER 9 CABLES AND CONNECTIONS — GENERAL INFORMATION.....	39	12.7 SeaTalk NG power cable extension	52
9.1 General cabling guidance.....	40	12.8 SeaTalk NG product loading	52
Cable types and length	40	12.9 SeaTalk NG power connection point.....	52
Cable routing and bend radius	40	12.10 SeaTalk NG system loading	53
Strain relief.....	40	12.11 Power distribution — SeaTalk NG.....	53
Cable shielding.....	40	12.12 12 Volt dc only	55
Suppression ferrites.....	41	12.13 Positive ground systems	55
CHAPTER 10 NETWORK CONNECTIONS	42	12.14 Product grounding.....	56
10.1 Connections overview	43	CHAPTER 13 SYSTEM CHECKS	57
10.2 Connecting SeaTalk NG cables.....	43	13.1 Post-installation checks.....	58
10.3 Evolution-Series minimum system example (ACU-100 / ACU-150).....	43	13.2 Autopilot system setup	58
10.4 Evolution-Series recommended system example (ACU-100 / ACU-150).....	44	13.3 Rudder damping levels and deadband angles.....	58
10.5 Evolution-Series minimum system example (ACU-200 / ACU-400).....	45	Rudder Damping level adjustments.....	59
10.6 Evolution-Series recommended system example (ACU-200 / ACU-300 / ACU-400).....	46	CHAPTER 14 TROUBLESHOOTING AND ALARMS.....	60
CHAPTER 11 PILOT CONTROLLER CONNECTIONS.....	47	14.1 LED diagnostic guidance	61
		14.2 LED indications.....	62
		Switching off sensor LEDs.....	62
		Find me	63

14.3 Error message troubleshooting	63	Alarm: PILOT STARTUP	67
Error: AUTO RELEASE	63	CHAPTER 15 OPERATION.....	68
Error: DRIVE STOPPED	63	15.1 Evolution-Series autopilot operation	
Error: NO RUDDER REFERENCE	64	instructions.....	69
Error: STALL DETECTED	64	CHAPTER 16 MAINTENANCE.....	70
Error: CLUTCH OVERLOAD	64	16.1 Service and maintenance	71
Error: CURRENT OVERLOAD	64	16.2 Routine equipment checks.....	71
Error: NO DATA.....	64	16.3 Product cleaning	71
Error: NO WIND DATA.....	64	CHAPTER 17 TECHNICAL SUPPORT	72
Error: NO SPEED DATA	65	17.1 Raymarine technical support and	
Error: NO COMPASS.....	65	servicing	73
Error: RATE GYRO FAIL.....	65	Viewing product information	74
Error: MOTOR POWER SWAPPED.....	65	17.2 Learning resources	74
Error: NO GPS DATA.....	65	CHAPTER 18 TECHNICAL SPECIFICATION	75
Error: JOYSTICK FAULT.....	65	18.1 Physical specification	76
Error: NO IPS (NO DRIVE DETECTED)	65	18.2 Power specification	76
Error: PILOT RESET NORMAL		18.3 Network specification	76
(UNEXPECTED HARDWARE RESET)	65	18.4 Sensor specification	76
Error: PILOT RESET EXCEPTION		18.5 Environmental specification	76
(UNEXPECTED SOFTWARE RESET).....	65	18.6 Conformance specification.....	76
14.4 Miscellaneous troubleshooting	66	CHAPTER 19 SPARES AND ACCESSORIES.....	77
14.5 Alarms	66	19.1 Spares	78
Alarm: OFF COURSE	66	19.2 Accessories.....	78
Alarm: WIND SHIFT	66	19.3 SeaTalk NG cables and accessories	79
Alarm: LOW BATTERY	66	APPENDIX A NMEA 2000 PGNS	83
Alarm: LARGE XTE.....	66	APPENDIX B EV-1 SOFTWARE RELEASE	
Alarm: CU DISCONNECTED	67	HISTORY	84
Alarm: WAYPOINT ADVANCE	67		
Alarm: ROUTE COMPLETE.....	67		
Alarm: NO DATA	67		

CHAPTER 1: IMPORTANT INFORMATION

Safety warnings



Warning: Autopilot installation

Correct performance of the vessel's steering is critical for safety, therefore it is **STRONGLY RECOMMENDED** that this product is installed by an Authorized Raymarine Service Representative. You will only receive full warranty benefits if you can show that an Authorized Raymarine Service Representative has installed and commissioned your autopilot system.



Warning: Maintain a permanent watch

Always maintain a permanent watch, this will allow you to respond to situations as they develop. Failure to maintain a permanent watch puts yourself, your vessel and others at serious risk of harm.



Warning: Ensure safe navigation

This product is intended only as an aid to navigation and must never be used in preference to sound navigational judgment. Only official government charts and notices to mariners contain all the current information needed for safe navigation, and the captain is responsible for their prudent use. It is the user's responsibility to use official government charts, notices to mariners, caution and proper navigational skill when operating this or any other Raymarine product.



Warning: Potential ignition source

This product is **NOT** approved for use in hazardous/flammable atmospheres. Do **NOT** install in a hazardous/flammable atmosphere (such as in an engine room or near fuel tanks).



Warning: Switch off power supply

Ensure that the vessel's power supply is switched **OFF** before starting to install this product. Do **NOT** connect or disconnect equipment with the power switched on, unless instructed to do so in this document.

Product warnings



Warning: Product grounding

Before applying power to this product, it **MUST** be correctly grounded, in accordance with the instructions provided.



Warning: Positive ground systems

Do **NOT** connect this unit to a system which has positive grounding.



Warning: Power supply voltage

Connecting this product to a voltage supply greater than the specified maximum rating may cause permanent damage to the unit. For the correct voltage, refer to the information label affixed to the product.

Caution: Power supply protection

When installing this product, ensure that the power source is adequately protected by means of a suitably-rated fuse or thermal circuit breaker.

Caution: Product cleaning

When cleaning products:

- Switch off power supply.
- Use a clean damp cloth to wipe clean.
- Do NOT use: abrasive, acidic, ammonia, solvent or other chemical-based cleaning products.
- Do NOT use a jet wash.

Caution: Service and maintenance

This product contains no user serviceable components. Please refer all maintenance and repair to authorized Raymarine dealers. Unauthorized repair may affect your warranty.

Regulatory notices

Disclaimer

Raymarine does not warrant that this product is error-free or that it is compatible with products manufactured by any person or entity other than Raymarine.

Raymarine is not responsible for damages or injuries caused by your use or inability to use the product, by the interaction of the product with products manufactured by others, or by errors in information utilized by the product supplied by third parties.

Third-party hardware, such as converters, adapters, routers, switches, Access Points etc., provided by third parties, may be made available directly to you by other companies or individuals under separate terms and conditions, including separate fees and charges. Raymarine UK Ltd or its affiliates have not tested or screened the third-party hardware.

Raymarine has no control over, and is not responsible for:

- (a) the content and operation of such third-party hardware; or
- (b) the privacy or other practices of such third-party hardware.

The fact that Raymarine's documentation may make reference to such third-party hardware does not indicate any approval or endorsement of any such third-party hardware. Raymarine may reference such third-party hardware only as a convenience.

THIS INFORMATION IS MADE AVAILABLE BY Raymarine ON THE BASIS THAT YOU EXCLUDE TO THE FULLEST EXTENT LAWFULLY PERMITTED ALL LIABILITY WHATSOEVER FOR ANY LOSS OR DAMAGE HOWSOEVER ARISING OUT OF THE USE OF THIS INFORMATION OR RELIANCE UPON THIS INFORMATION.

Raymarine does not exclude **Raymarine's** liability (if any) to you for personal injury or death resulting from **Raymarine UK Ltd** negligence, for fraud or for any matter which it would be illegal to exclude or to attempt to exclude.

Water ingress

Water ingress disclaimer

Although the waterproof rating capacity of this product meets the stated water ingress protection standard (refer to the product's *Technical Specification*), water intrusion and subsequent equipment failure may occur if the product is not installed correctly or subjected to high-pressure washing. Raymarine will not warrant products subjected to high-pressure washing.

Suppression ferrites

- Raymarine cables may be pre-fitted or supplied with suppression ferrites. These are important for correct EMC performance. If ferrites are supplied separately to the cables (i.e. not pre-fitted), you must fit the supplied ferrites, using the supplied instructions.
- If a ferrite has to be removed for any purpose (e.g. installation or maintenance), it must be replaced in the original position before the product is used.
- Use only ferrites of the correct type, supplied by Raymarine or its authorized dealers.
- Where an installation requires multiple ferrites to be added to a cable, additional cable clips should be used to prevent stress on the connectors due to the extra weight of the cable.

Connections to other equipment

Requirement for ferrites on non-Raymarine cables:



If your Raymarine equipment is to be connected to other equipment using a cable not supplied by Raymarine, a suppression ferrite **MUST** always be attached to the cable near the Raymarine unit.

For more information, refer to your third-party cable manufacturer.

Declaration of Conformity

Raymarine UK Ltd declares that the radio equipment type products listed below are in conformity with the relevant sections of the listed designated standards and / or other normative documents:

- Evolution-Series EV-1 *Attitude Heading Reference Sensor* (AHRS), part number: E70096

Region	Standard	Mark
UK	EMC Regulations 2016	
EU	Radio Equipment Directive 2014/53/EU	

The original Declaration of Conformity certificate may be viewed on the relevant product page at: www.bit.ly/ev1-docs

PSTI Compliance

For products sold into the United Kingdom (UK), use the following link to obtain the product's Statement of Compliance with the *Product Security and Telecommunications Infrastructure* (PSTI) Regulations:

Visit the following web address and enter the product's model name or number (SKU) into the provided search field:

- www.bit.ly/rym-sec-com

Product disposal

Dispose of this product in accordance with the WEEE Directive.

The Waste Electrical and Electronic Equipment (WEEE) Directive requires the recycling of waste electrical and electronic equipment which contains materials, components and substances that may be hazardous and present a risk to human health and the environment when WEEE is not handled correctly.

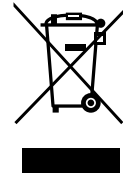

Equipment marked with the crossed-out wheeled bin symbol indicates that the equipment should not be disposed of in unsorted household waste. Local authorities in many regions have established collection schemes under which residents can dispose of waste electrical and electronic equipment at a recycling center or other collection point. For more information about suitable collection points for waste electrical and electronic equipment in your region, refer to the Raymarine website: <https://bit.ly/rym-recycling>

Warranty policy and registration

Visit the Raymarine website to **read the latest warranty policy**, and **register** your product's warranty online: www.bit.ly/rym-warranty

It is important that you register your product to receive full warranty benefits. Your product package includes a barcode label indicating the serial number of the unit. This serial number is also provided on a label affixed to the product itself. You will need this serial number when registering your product online.

IMO and SOLAS

The equipment described within this document is intended for use on leisure marine boats and workboats NOT covered by International Maritime Organization (IMO) and Safety of Life at Sea (SOLAS) Carriage Regulations.

Technical accuracy

To the best of our knowledge, the information in this document was correct at the time it was produced. However, Raymarine cannot accept liability for any inaccuracies or omissions it may contain. In addition, our policy of continuous product improvement may change specifications without notice. As a result, Raymarine cannot accept liability for any differences between the product and this document. Please check the Raymarine website to ensure you have the most up-to-date version(s) of the documentation for your product: www.docs.raymarine.com

Publication copyright

Copyright ©2025 Raymarine UK Ltd. All rights reserved. No parts of this material may be copied, translated, or transmitted (in any medium) without the prior written permission of Raymarine UK Ltd.

CHAPTER 2: DOCUMENT INFORMATION

CHAPTER CONTENTS

- 2.1 Applicable products — page 12
- 2.2 Product documentation — page 12
- 2.3 Document illustrations — page 12
- 2.4 Applicable software version — page 12
- 2.5 New software improvements — page 12

2.1 Applicable products

This document is applicable to the following products:

EV-1 (**E70096**) — Attitude Heading Reference Sensor (AHRS).

2.2 Product documentation

Applicable documentation

The following documentation is applicable to your product:

Document	Description
87472	EV-1 Autopilot Installation Instructions (this document)
87170	EV-1 Autopilot Mounting Template (for surface or wall mounting).

Related documentation

The following documentation is related to your product:

ACU-Series Autopilot documentation:

Document	Description
87473	ACU-100 & ACU-150 Autopilot Installation Instructions
87474	ACU-200 Autopilot Installation Instructions
87475	ACU-300 Autopilot Installation Instructions
87476	ACU-400 Autopilot Installation Instructions

Autopilot controller documentation:

Document	Description
81402	p70 / p70R / p70s / p70Rs Commissioning & Operation Instructions
81406	LightHouse 4 Operation Instructions
81370	LightHouse 3 Operation Instructions
81360	LightHouse 2 Operation Instructions

SeaTalk NG documentation:

Document	Description
81300	SeaTalk NG reference manual: Planning and connection of systems based around the SeaTalk NG network.
87121	SeaTalk 1 — SeaTalk NG converter installation instructions: Installation and connection of the SeaTalk 1 — SeaTalk NG converter.

All documents are available to download from the Raymarine website: www.bit.ly/rym-docs

2.3 Document illustrations

Your product and if applicable, its user interface may differ slightly from that shown in the illustrations in this document, depending on product variant and date of manufacture.

All images are provided for illustration purposes only.

2.4 Applicable software version

This document has been updated to reflect products running EV-Series software version: **v3.17**.

Check the website for the latest software and user manuals:

- www.bit.ly/rym-software
- www.bit.ly/rym-docs

2.5 New software improvements

List of general improvements introduced in **v3.17** of the EV-1 software. Software releases include any combination of new features, performance improvements, and bug fixes.

EV-1, v3.17

(Software release date: *February 2024*)

EV-1 software download link

www.bit.ly/rym-software

General improvements:

Added support for a new LED indicator 'Switch off' setting which can be toggled via a networked LightHouse 4 multifunction display (running software version v4.6.74 or later). For more information, refer to: [p.62 — Switching off sensor LEDs](#)

Added support for a new LED indicator 'Find me' setting which can be toggled via a networked LightHouse 4 multifunction display (running software version v4.6.74 or later). For more information, refer to: [p.63 — Find me](#)

Added ability to Steer to Target wind angle from polar, using a compatible autopilot controller.

Fixed issues:

No bug fixes in this release.

CHAPTER 3: PRODUCT AND SYSTEM OVERVIEW

CHAPTER CONTENTS

- 3.1 Product overview — page 15
- 3.2 SeaTalk NG — page 15
- 3.3 Multiple data sources (MDS) — page 15
- 3.4 Required additional components — page 16
- 3.5 Evolution-Series minimum system example (ACU-100 / ACU-150) — page 17
- 3.6 Evolution-Series minimum system example (ACU-200 / ACU-400) — page 17
- 3.7 Evolution-Series recommended system example (ACU-100 / ACU-150) — page 18
- 3.8 Evolution-Series recommended system example (ACU-200 / ACU-300 / ACU-400) — page 19
- 3.9 Software updates — page 20

3.1 Product overview

The Evolution-Series is a system of electronic components that give you autopilot control of your vessel's steering system.

In conjunction with a compatible Autopilot controller, the Evolution-Series components enable you to directly control the vessel's steering system and provide navigation commands, such as navigating to pre-determined tracks and waypoints for example.

The Evolution-Series system provides a number of features to ensure ease of installation and minimal setup:

- **Flexible mounting options** — The EV-1 sensor can be mounted horizontally on a flat deck or alternatively on a bracket, for mounting on a mast, wall or other vertical surface.

Note:

The arrow on the front of the EV-1 sensor must be parallel with the centerline of the vessel and pointing towards the vessel's bow.

- **Simple connections** — All Evolution-Series system components are connected to a single SeaTalk NG backbone.
- **High accuracy** — Accurate course-keeping, to within +/- 2 degrees, in all conditions.
- **Built-in heading and attitude sensor** — No additional fluxgate compass required.
- **Automatic setup** — No calibration required. The Rudder Gain, Rudder Damping, Counter Rudder, and compass calibration settings required by existing autopilots are no longer necessary.

The Evolution-Series system consists of the following components:

Component	Purpose
EV-1 AHRS (Attitude Heading Reference Sensor):	The primary heading sensor and course computer, incorporating an attitude 9-axis sensor. This sensor replaces the fluxgate compass typical in existing autopilot systems.
ACU (Actuator Control Unit):	Houses the main power and drive electronics for direct connection to a vessel's steering system.

3.2 SeaTalk NG

SeaTalk NG (*Next Generation*) is an enhanced cable system for the connection of compatible marine instruments and equipment. It replaces the older SeaTalk 1 and SeaTalk 2 cable systems.

SeaTalk NG utilizes a single backbone which compatible equipment connects to using a spur. Data and power are carried within the backbone. Devices that have a low power draw can be powered from the network, although high current equipment will need to have a separate power connection.

SeaTalk NG is a proprietary extension to NMEA 2000 and the proven CAN bus technology. Compatible NMEA 2000, SeaTalk 1 and SeaTalk 2 devices can also be connected using the appropriate interfaces or adaptor cables as required.

3.3 Multiple data sources (MDS)

MDS is a Raymarine scheme for managing multiple sources of identical data types on the same network (e.g.: in an MFD network you may have more than one source of GNSS (GPS) position data).

The MFD will automatically select a preferred data source (device) to use for that data type.

MDS can be used for the following data types:

- *Depth*
- *Speed through water*
- *Heading*
- *GPS*
- *GPS Datum*
- *Wind*
- *Time & Date*
- *Water temperature* (chartplotters only)

If you do not want to use the automatically selected data source you can manually select your preferred data source.

Note:

For MDS to be available on your system, all products in the system that report data must be MDS-compliant. The system will report any products that are NOT MDS-compliant. It may be possible to upgrade the software for these non-compliant products, to make them compliant. Visit the Raymarine website to obtain the latest software for your products: <https://bit.ly/rym-software>. If MDS-compliant software is not available for the product and you do NOT want to use the system's preferred data source, you must remove any non-compliant products from the system. You should then be able to select your preferred data source. Once you have completed setting up your preferred data sources, you may be able to add non-compliant products back into the system.

Multiple data source exceptions

With the Evolution-Series system, there are a number of important exceptions to the handling of multiple sources of certain types of data.

Specifically:

- **Heading data** — If a non-Evolution-Series source of heading data is designated by the user, the Evolution-Series system components will combine this heading data with its own gyro and accelerometer data, and then use the improved heading data. This combined heading data will also be available to other equipment on the SeaTalk NG bus.
- **Rudder angle data** — Where there are multiple sources of rudder reference information, the Evolution-Series system components will ignore rudder angle inputs from any rudder reference units that are NOT connected directly to the ACU-Series unit.

3.4 Required additional components

To complete your autopilot system, you will need the following components and data sources in addition to the Evolution-Series components.

Essential:

- A compatible autopilot controller. For more information, refer to:
 - [p.21 — Compatible autopilot controllers](#)

- A drive unit appropriate for your vessel, EV-1 and ACU-Series unit. For more information, refer to documentation supplied with your ACU-Series unit: [p.11 — Document information](#)
- An ACU power cable (not supplied).
- A SeaTalk NG backbone.
- **Essential for ACU-300:** A rudder angle reference sensor / transducer (M81105).
- **Essential for ACU-300:** You must also ensure that the ACU-300 is running software version v3.13 or later.

Recommended:

- A rudder angle reference sensor / transducer (M81105). **Highly recommended** to ensure optimum autopilot performance.
- A compatible speed data source. The autopilot uses speed data when making calculations relating to navigation. As a minimum, this information must come from a GNSS (GPS) receiver providing SOG (Speed Over Ground) data, or ideally from a dedicated speed sensor.
- A compatible wind data source (only required for sailing vessels). The autopilot uses wind vane data to steer relative to a specified wind angle. This data must come from an analog wind transducer connected to the SeaTalk NG backbone.

Note:

The system components listed above are “recommended” as they help to provide optimum performance for autopilot systems when used in conjunction with the “essential” components listed. However, these “recommended” components are not included in all autopilot products or system packs. Consult the Raymarine website or your local dealer for a full list of the components included with your autopilot system.

Optional:

- A position data source. The autopilot uses position data when following routes and calculating the optimum course to steer. This data is typically supplied via a GNSS (GPS) receiver on the SeaTalk NG backbone.

3.5 Evolution-Series minimum system example (ACU-100 / ACU-150)

The following example provides an overview of an Evolution-Series *minimum system*, including the available connections and types of devices that **must** be connected to your Evolution-Series system when an ACU-100 or ACU-150 is present.

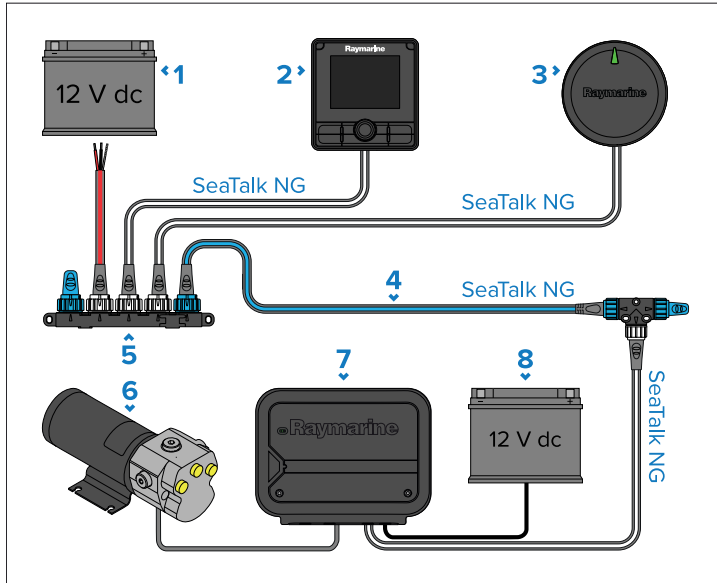

Note:

A rudder angle reference sensor / transducer is a highly recommended system component (not shown in the drawing above, but available separately as M81105).

1. 12 V dc power supply (providing power to the SeaTalk NG backbone).
2. Autopilot controller (p70Rs shown).
3. EV-1 sensor.
4. SeaTalk NG backbone.
5. SeaTalk NG 5-way block.

6. Drive unit (hydraulic pump shown).
7. ACU-100 / ACU-150.
8. 12 V dc power supply (providing power to the ACU-100 / ACU-150).

3.6 Evolution-Series minimum system example (ACU-200 / ACU-400)

The following example provides an overview of an Evolution-Series *minimum system*, including the available connections and types of devices that **must** be connected to your Evolution-Series system when an ACU-200 or ACU-400 is present.

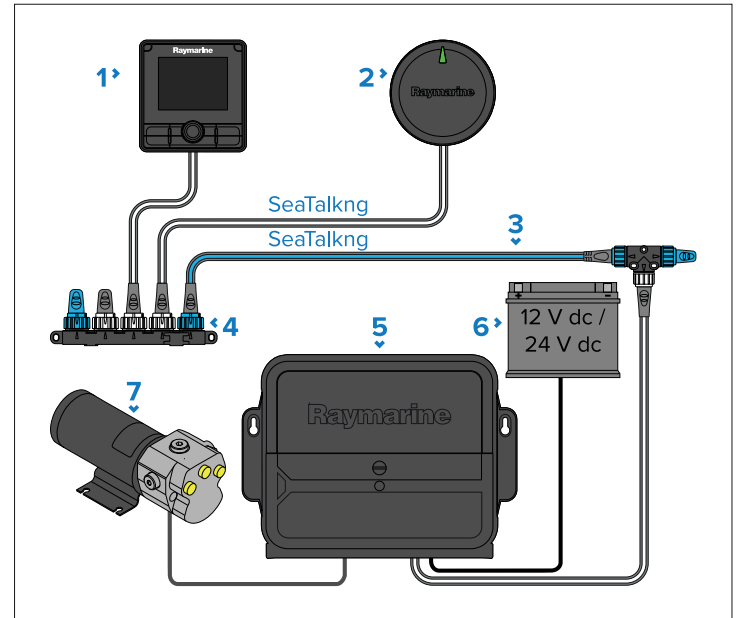

Note:

A rudder angle reference sensor / transducer is a highly recommended system component (not shown in the drawing above, but available separately as M81105).

1. Autopilot controller (e.g. p70Rs).
2. EV-1 sensor.
3. SeaTalk NG backbone.
4. SeaTalk NG 5-way block.
5. ACU-200 / ACU-400.
6. 12 V / 24 V dc power supply (providing power to the ACU-200 / ACU-400 and SeaTalk NG backbone).
7. Drive unit (e.g. hydraulic pump).

3.7 Evolution-Series recommended system example (ACU-100 / ACU-150)

The following example provides an overview of a *recommended system*, including the available connections and types of devices that can be connected to your system when an ACU-100 or ACU-150 is present.

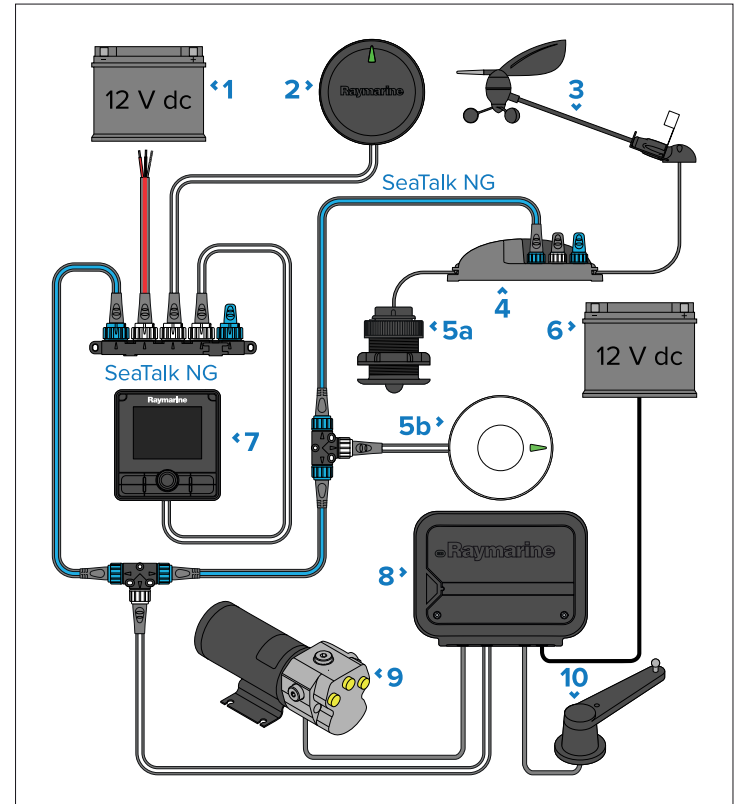

1. 12 V dc power supply (providing power to SeaTalk NG backbone).
2. EV-1 sensor.
3. Wind transducer (only required for Sailing vessels).
4. iTC-5 converter.

5. Speed data source:
 - a. Speed transducer (providing STW data), or
 - b. GNSS (GPS) Receiver (providing SOG data).
6. 12 V dc power supply (providing power to the ACU-100 / ACU-150).
7. Autopilot controller (p70Rs shown).
8. ACU-100 / ACU-150.
9. Drive unit (hydraulic pump shown).
10. Rudder angle reference sensor / transducer (M81105).

3.8 Evolution-Series recommended system example (ACU-200 / ACU-300 / ACU-400)

The following example provides an overview of an Evolution-Series *recommended system*, including the available connections and types of devices that can be connected to your autopilot system when an ACU-200 or ACU-400 is present, which **must** be connected to your Evolution-Series system when an ACU-300 is present.

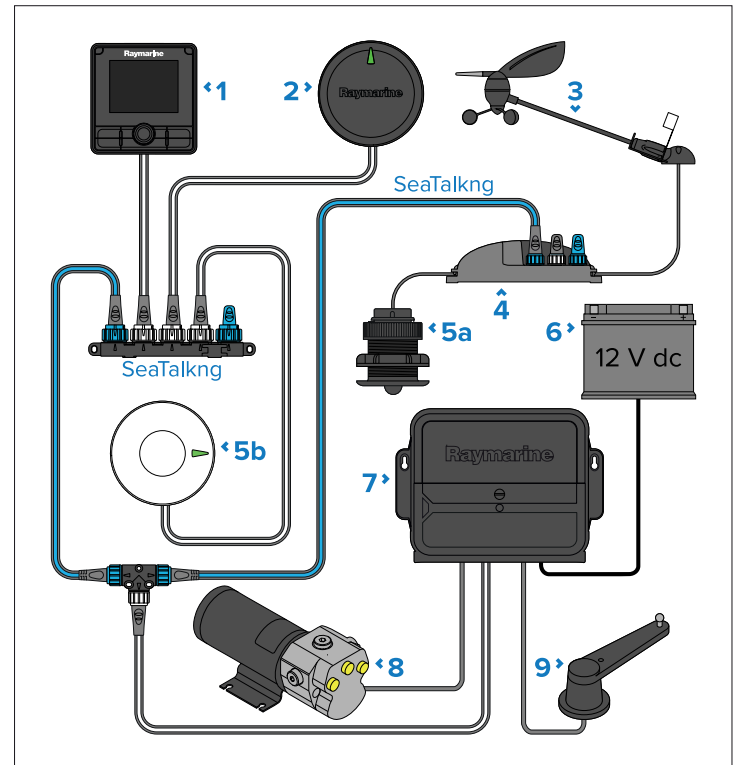

1. Autopilot controller (e.g. p70Rs).
2. EV-1 sensor.
3. Wind transducer (only required for Sailing vessels).

4. iTC-5 converter.
5. Speed data source:
 - a. Speed transducer (providing STW data), or
 - b. GNSS (GPS) Receiver (providing SOG data).
6. 12 V / 24 V dc power supply (providing power to the ACU and SeaTalk NG backbone).
7. ACU-200 / ACU-300 / ACU-400.
8. Drive unit (e.g. hydraulic pump).
9. Rudder angle reference sensor / transducer (M81105) — This is **essential for ACU-300** systems, and highly recommended for all other systems.

3.9 Software updates

Product software updates may be made available which add new features and improve existing functionality. It's important to ensure that you have the latest software for your products by regularly checking the Raymarine website for new software releases.

To check for the latest software updates and the software update procedure for your specific product(s), refer to: www.bit.ly/rym-software

Unless otherwise stated, software updates for Raymarine products are performed using a Raymarine MFD / chartplotter.

- Where applicable, you should always backup your user data and settings before performing a software update.
- To update SeaTalk NG products, you must use the datamaster MFD / chartplotter which is physically connected to the SeaTalk NG backbone.
- Ethernet (RayNet) products can be updated from any MFD / chartplotter on the same network as the product to be updated.
- In order to perform a software update, any connected Autopilot or Radar must be switched to Standby.
- The MFD / chartplotter “Check online” feature is only available when connected to the Internet.

Note:

If in doubt as to the correct procedure for updating your product software, refer to your dealer or Raymarine technical support.

Caution: Installing software updates

- The software update process is carried out at your own risk. Before initiating the update process ensure you have backed up any important files.
- Ensure that the product(s) has a reliable power supply and that the update process is not interrupted.
- Damage caused by an incomplete update is not covered by Raymarine warranty.
- By downloading the software update package, you agree to these terms.

CHAPTER 4: COMPATIBLE AUTOPILOT CONTROLLERS

CHAPTER CONTENTS

- 4.1 Compatible autopilot controllers — page 22
- 4.2 Compatible SeaTalk NG autopilot controllers — page 22
- 4.3 Compatible SeaTalk 1 autopilot controllers — page 23
- 4.4 Compatible MFD / chartplotter autopilot controllers — page 24

4.1 Compatible autopilot controllers

Autopilot operation requires a compatible display, which acts as the “control head” or “control unit” for the autopilot system.

The following types of Autopilot controller are supported:

- Compatible Raymarine SeaTalk NG autopilot controllers.
- Compatible Raymarine SeaTalk 1 autopilot controllers, when connected via a SeaTalk 1 to SeaTalk NG converter.
- Compatible Raymarine multifunction display / chartplotter.

More than one autopilot controller can be used to control your autopilot system — for example, you may have a SeaTalk NG autopilot controller at the helm, and a multifunction display / chartplotter at the flybridge.

For a list of compatible displays, refer to the information provided in this chapter.

Note:

SeaTalk 1 autopilot controllers may have limited functionality.

4.2 Compatible SeaTalk NG autopilot controllers

List of compatible SeaTalk NG autopilot controllers, which act as the “control head” or “control unit” for the autopilot system.



	Description	Required software version
1	p70s (E70328)	<i>Latest software version.</i>
2	p70Rs (E70329)	<i>Latest software version.</i>
3	p70 (E22166)	<i>v2.11, or later.</i>
4	p70R (E22167)	<i>v2.11, or later.</i>
5	ST70 (E22105)	<i>Latest software version.</i>
6	ST70+ (E22115)	<i>Latest software version.</i>

4.3 Compatible SeaTalk 1 autopilot controllers

List of compatible SeaTalk 1 autopilot controllers, which act as the “control head” or “control unit” for the autopilot system.

SeaTalk 1 autopilot controllers must be connected via a SeaTalk 1 to SeaTalk NG converter.

Note:

SeaTalk 1 autopilot controllers may have limited functionality.



	Description	Required software version
1	ST6002 (E12098-P / E12100-P)	<i>Latest software version.</i>
2	ST7002 (E12099-P / E12182)	<i>Latest software version.</i>
3	ST8002 (E12119-P / E12183)	<i>Latest software version.</i>
4	S100 (repeat controller only) (E15024)	<i>Latest software version.</i>
5	SmartController (repeat controller only) (E15023)	<i>Latest software version.</i>

4.4 Compatible MFD / chartplotter autopilot controllers

List of compatible Raymarine MFD / chartplotter autopilot controllers, which can act as the “control head” or “control unit” for the autopilot system.

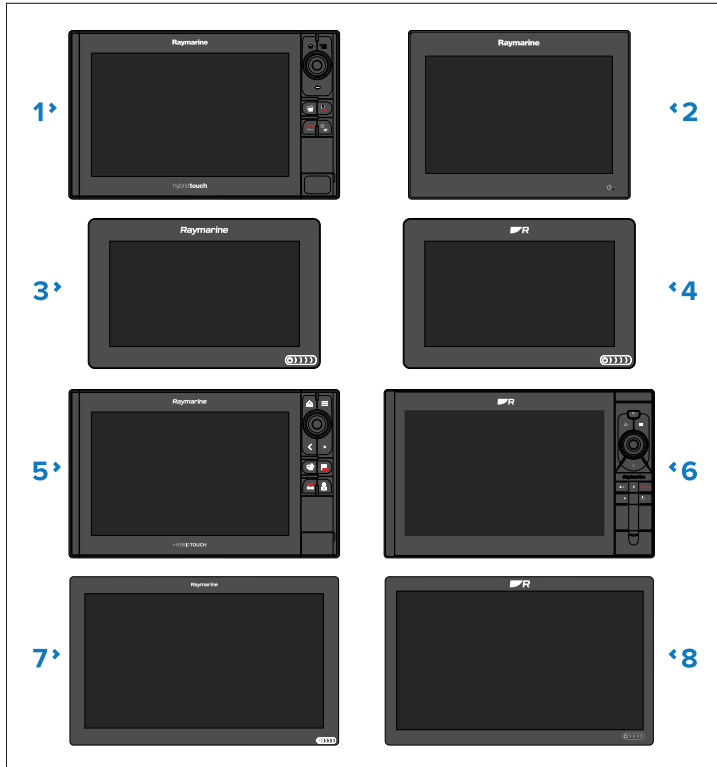

	Description	Required software version
1	eS-Series	<ul style="list-style-type: none"> • <i>LightHouse 3, version v3.1.96 (or later)</i> • <i>LightHouse 2, version v14.36 (or later)</i>
2	gS-Series	<ul style="list-style-type: none"> • <i>LightHouse 3, version v3.1.96 (or later)</i> • <i>LightHouse 2, version v14.36 (or later)</i>
3	Axiom	<ul style="list-style-type: none"> • <i>LightHouse 4, version v4.4.70 (or later)</i> • <i>LightHouse 3, version v3.1.96 (or later)</i>
4	Axiom+	<ul style="list-style-type: none"> • <i>LightHouse 4, version v4.4.70 (or later)</i> • <i>LightHouse 3, version v3.12.199 (or later)</i>
5	Axiom Pro	<ul style="list-style-type: none"> • <i>LightHouse 4, version v4.4.70 (or later)</i> • <i>LightHouse 3, version v3.1.96 (or later)</i>
6	Axiom 2 Pro	<ul style="list-style-type: none"> • <i>LightHouse 4, version v4.4.70 (or later)</i>
7	Axiom XL	<ul style="list-style-type: none"> • <i>LightHouse 4, version v4.4.70 (or later)</i> • <i>LightHouse 3, version v3.1.96 (or later)</i>
8	Axiom 2 XL	<ul style="list-style-type: none"> • <i>LightHouse 4, version v4.4.70 (or later)</i>

CHAPTER 5: PARTS SUPPLIED

CHAPTER CONTENTS

- 5.1 Parts supplied — page 26

5.1 Parts supplied

The following parts are supplied with your product:

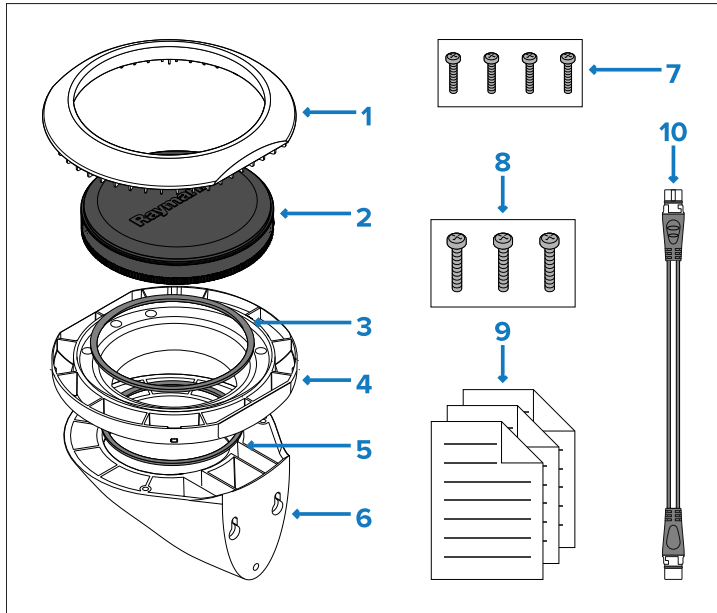

Description	
1	Mounting trim.
2	EV sensor.
3	Large sealing ring.
4	Mounting tray.
5	Small sealing ring.
6	Wall mounting bracket.
7	Screws for deck or bracket mounting.
8	Screws for wall bracket.

Description	
9	Documentation pack.
10	SeaTalk NG spur cable, 1 m (3.3 ft).

CHAPTER 6: PRODUCT DIMENSIONS

CHAPTER CONTENTS

- [6.1 Product dimensions — page 28](#)

6.1 Product dimensions

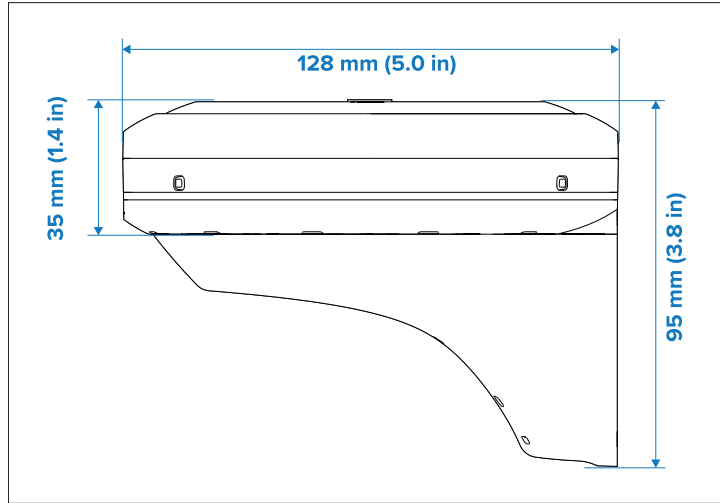

CHAPTER 7: LOCATION REQUIREMENTS

CHAPTER CONTENTS

- 7.1 Warnings and cautions — page 30
- 7.2 Location requirements — page 30
- 7.3 Compass safe distance — page 31
- 7.4 EMC installation guidelines — page 31

7.1 Warnings and cautions

Important:

Before proceeding, ensure that you have read and understood the warnings and cautions provided in the following section of this document:

- p.8 – Important information



Warning: Potential ignition source

This product is NOT approved for use in hazardous/flammable atmospheres. Do NOT install in a hazardous/flammable atmosphere (such as in an engine room or near fuel tanks).

7.2 Location requirements

The installation location must take into account the following requirements:

- The unit can be installed above or below decks.
- The unit must be mounted on a horizontal and level surface. The unit may be mounted upright or upside-down, but the unit must be level within 5° of pitch and 5° of roll (compared with the vessel's neutral position when at rest and normally loaded).

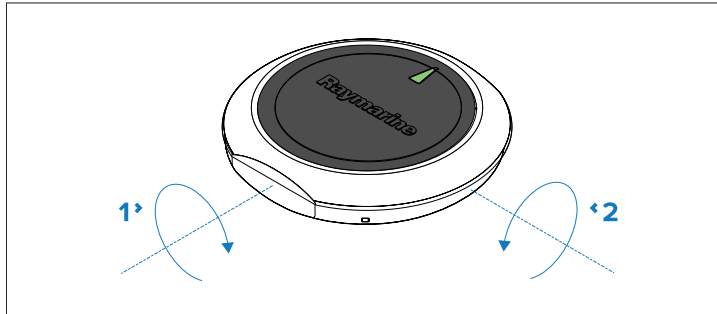

1. Roll
2. Pitch

- The unit can be mounted on a vertical surface such as a bulkhead or mast etc, using the supplied bracket.
- The unit location must be at least 1 m (3 ft.) away from any source of magnetic interference, such as compasses and electrical cables.
- Choose a location where the unit will be safe from physical damage and excessive vibration.
- Choose a location where the unit will not be subjected to a load or force.
- Mount away from any source of heat or potential flammable hazards, such as fuel vapor.
- The unit should be mounted in a location where the diagnostics LED is viewable.
- The unit must be mounted with the LED 'arrow' on the top of the unit pointing towards the vessel's bow and must be in parallel alignment with the longitudinal axis (centerline) of the vessel.

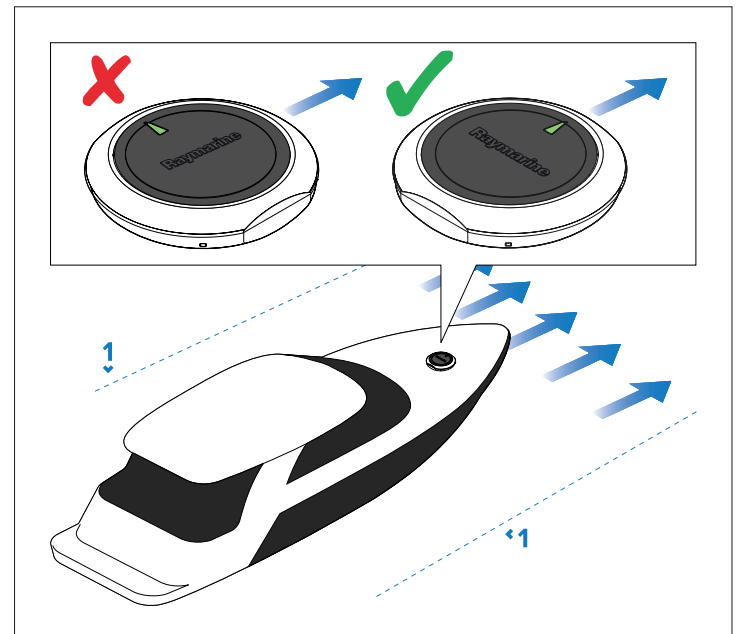

1. Vessel's longitudinal axis.

7.3 Compass safe distance

To prevent potential interference with the vessel's magnetic compasses, ensure an adequate distance is maintained from the product.

When choosing a suitable location for the product, you must aim to maintain a distance of **at least 1 m (3.3 ft.)** in all directions from any compasses.

For some smaller vessels it may not be possible to locate the product this far away from a compass. In this situation, when choosing the installation location for your product, ensure that the compass is not affected by the product when it is in a powered on state.

7.4 EMC installation guidelines

Raymarine equipment and accessories conform to the appropriate Electromagnetic Compatibility (EMC) regulations, to minimize electromagnetic interference between equipment and minimize the effect such interference could have on the performance of your system.

Correct installation is required to ensure that EMC performance is not compromised.

Note:

In areas of extreme EMC interference, some slight interference may be noticed on the product. Where this occurs the product and the source of the interference should be separated by a greater distance.

For **optimum** EMC performance we recommend that wherever possible:

- Raymarine equipment and cables connected to it are:
 - At least 1 m (3.28 ft) from any equipment transmitting or cables carrying radio signals e.g. VHF radios, cables and antennas. In the case of SSB radios, the distance should be increased to 2 m (6.6 ft).
 - More than 2 m (6.56 ft) from the path of a radar beam. A radar beam can normally be assumed to spread 20 degrees above and below the radiating element.

- The product is supplied from a separate battery from that used for engine start. This is important to prevent erratic behavior and data loss which can occur if the engine start does not have a separate battery.
- Raymarine specified cables are used.
- Cables are not cut or extended, unless doing so is detailed in the installation manual.

Note:

Where constraints on the installation prevent any of the above recommendations, always ensure the maximum possible separation between different items of electrical equipment, to provide the best conditions for EMC performance throughout the installation.

Electromagnetic interference safe distance

To prevent potential electromagnetic interference with the product, ensure an adequate distance is maintained from any magnetic objects or materials (e.g. VHF radio, audio speakers, power cables).

When choosing a suitable location for the product you must aim to maintain a distance of at least 1 m (3.3 ft) in all directions from any magnetic objects or materials:

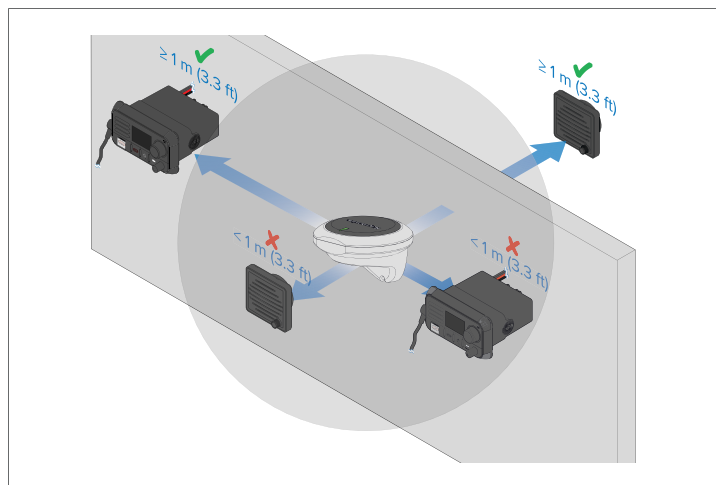

For some smaller vessels it may not be possible to locate the product this far away from a magnetic object. In this situation, when choosing the installation location for your product, ensure that the product is not affected by the magnetic object when it is in a powered on state.

CHAPTER 8: MOUNTING

CHAPTER CONTENTS

- 8.1 Tools required for installation — page 34
- 8.2 Fixing screw suitability — page 34
- 8.3 Surface mounting — page 34
- 8.4 Surface mounting using the riser — page 35
- 8.5 Bracket mounting — page 36
- 8.6 Releasing the product from the bracket — page 38

8.1 Tools required for installation

Product installation requires the following tools:

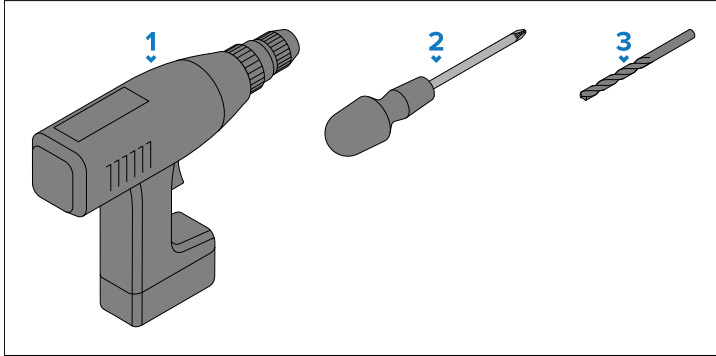

1. Power drill.
2. Pozi drive screwdriver.
3. Drill bit.

Note:

The appropriate drill bit size is dependent on the thickness and material of the mounting surface.

8.2 Fixing screw suitability

Important:

The fixing screws supplied may not be suitable for your mounting surface. Please check the security and integrity of the mounted product before finalizing your installation. If necessary, obtain replacement or additional mounting screws to ensure a secure installation.

8.3 Surface mounting

The supplied deck mounting kit is used to surface mount the unit.

Ensure that the chosen location meets the product's location requirements. For more information, refer to:

[p.29 – Location requirements](#)

Important:

The installation must only be performed with the vessel either on a hard standing, or tied-up alongside a pontoon or berth.

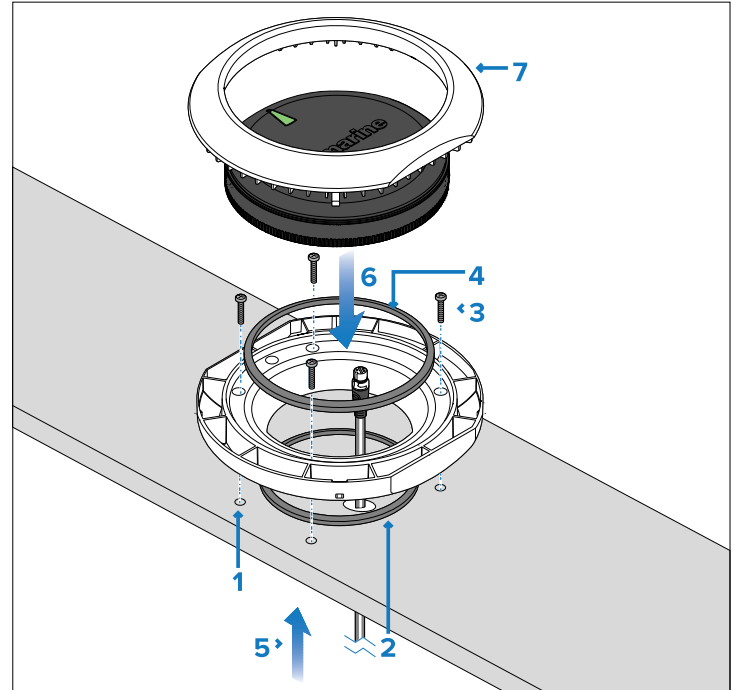

1. Using the mounting tray template (87170), drill 4 holes in the mounting surface, plus a 22 mm (7/8 in) hole for the SeaTalk NG cable.
2. Place the small sealing ring in the groove located on the bottom of the mounting tray.
3. Secure the tray to the mounting surface using the 4 fixings supplied.
4. Place the large sealing ring into the groove on the upper side of the mounting tray.
5. Pull the SeaTalk NG cable through the mounting surface hole and the mounting tray. Plug in the cable connector on the underside

of the unit and secure by rotating the locking collar clockwise 2 clicks.

6. Insert the unit into the mounting tray, ensuring the tabs in the mounting tray are slotted into the grooves around the edge of the unit.

Important:

The unit must be mounted with the LED 'arrow' in parallel alignment with the longitudinal axis (centerline) of the vessel and be pointing towards the vessel's bow.

7. Place the mounting trim over the unit slightly offset, and then twist the mounting trim clockwise until it locks into position.

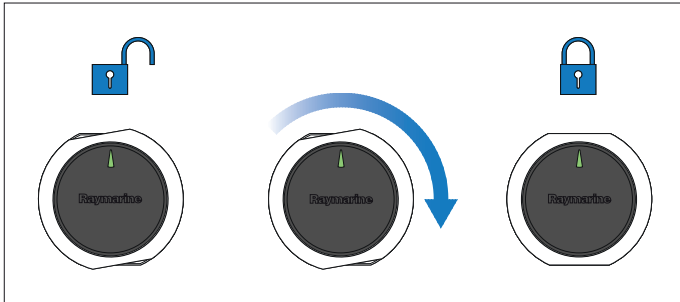

8.4 Surface mounting using the riser

The optional deck mounting kit (A80437) can be used to raise the product from the mounting surface, for installations where the cabling needs to be above-surface.

The wall bracket is not required when using the riser.

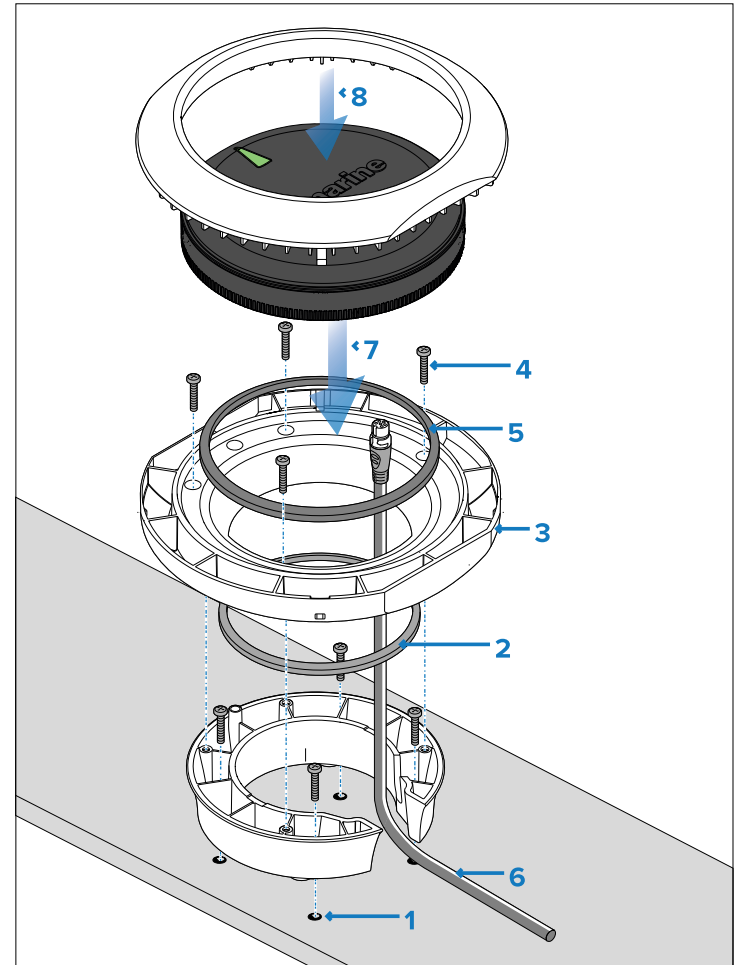

1. Use the deck mount riser template (87280) provided with the kit (A80437) to drill 4 holes in the mounting surface. Secure the riser to the mounting surface using the 4 supplied fixings.
2. Place the small sealing ring in the groove located on the bottom of the mounting tray.
3. Position the mounting tray on top of the riser.
4. Secure the mounting tray to the riser using 3 supplied fixings.
5. Place the large sealing ring into the groove on the upper side of the mounting tray.
6. Pull the SeaTalk NG cable through the riser and mounting tray. Plug in the cable connector on the underside of the product and secure by rotating the locking collar clockwise 2 clicks.

Note:

If there is not enough space in the riser to accommodate the cable and to plug the SeaTalk NG spur cable into the product, you may need to obtain a spur cable with a right-angled elbow connector (A06081) or a right-angled elbow adaptor (A06077).

7. Insert the product into the mounting tray, ensuring the tabs in the mounting tray are slotted into the grooves around the edge of the product.

Note:

When fitting the product to the tray, ensure that the orientation of the LED “arrow” at the top of the product is correct. For information on the correct LED orientation, refer to the *Location requirements* chapter.

8. Place the mounting trim over the product slightly offset, and then twist the mounting trim clockwise until it locks into position.

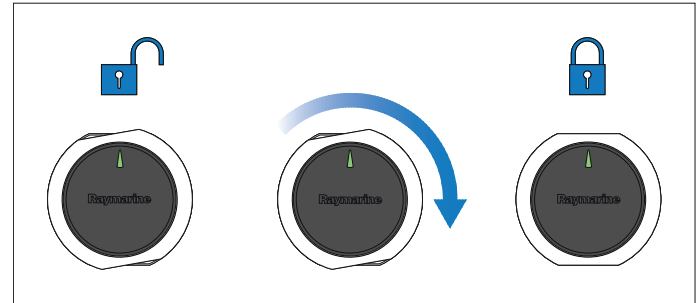

8.5 Bracket mounting

The supplied deck mounting kit is used to mount the unit on a vertical surface.

Ensure that the chosen location meets the product’s location requirements. For more information, refer to:

[p.29 – Location requirements](#)

Important:

The installation must only be performed with the vessel either on a hard standing, or tied-up alongside a pontoon or berth.

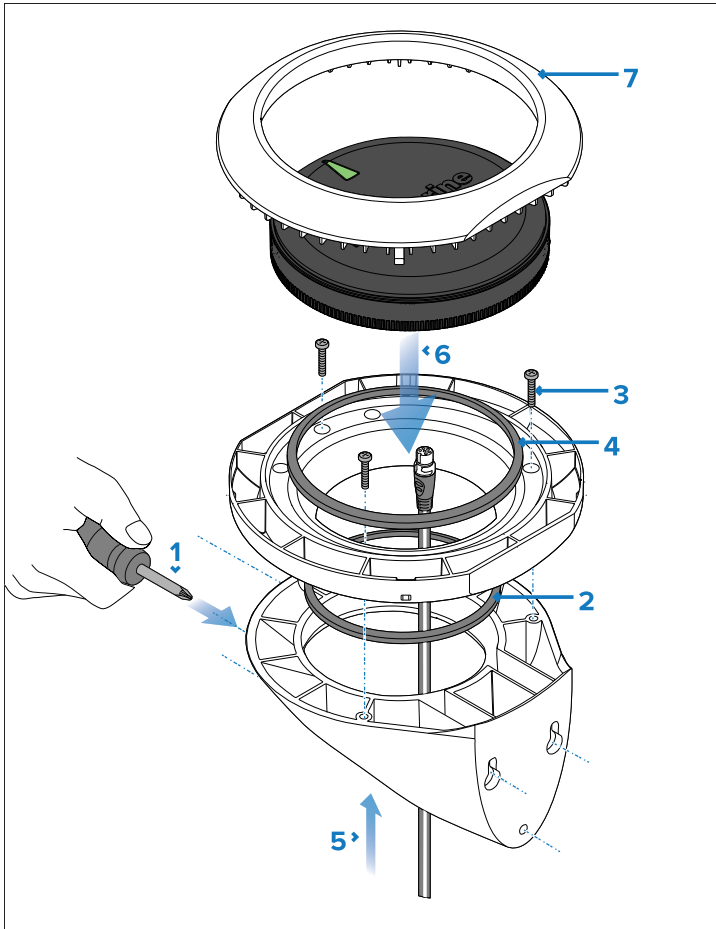

1. Use the mounting bracket template (87170) to drill 3 pilot holes in the vertical mounting surface. Secure the mounting bracket to the surface using the supplied screws.
2. Place the small sealing ring in the groove located on the bottom of the mounting tray.
3. Secure the tray to the bracket using 3 of the supplied screws in the positions indicated in the illustration above.

4. Place the large sealing ring into the groove on the upper side of the mounting tray.
5. Pull the SeaTalk NG cable through the center of the bracket and tray. Plug in the cable connector on the underside of the unit and secure by rotating the locking collar clockwise 2 clicks.
6. Insert the unit into the mounting tray, ensuring the tabs in the mounting tray are slotted into the grooves around the edge of the unit.

Important:

The unit must be mounted with the LED 'arrow' in parallel alignment with the longitudinal axis (centerline) of the vessel and be pointing towards the vessel's bow.

7. Orientate the mounting trim so that the release hole is accessible when mounted.

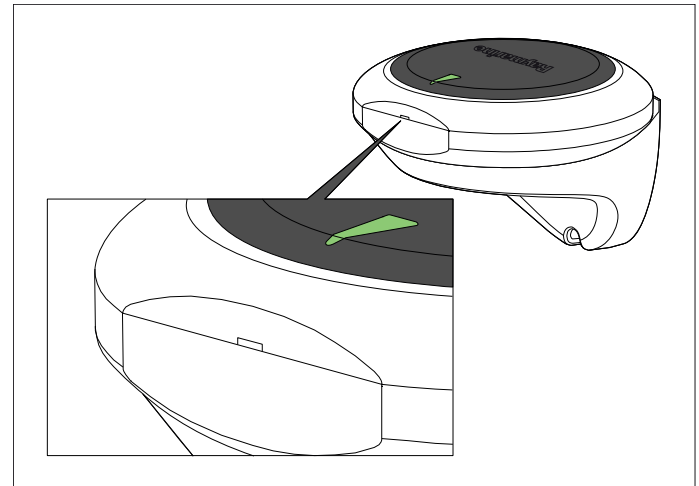

- Place the mounting trim over the unit slightly offset, and then twist the Mounting trim clockwise until it locks into position.

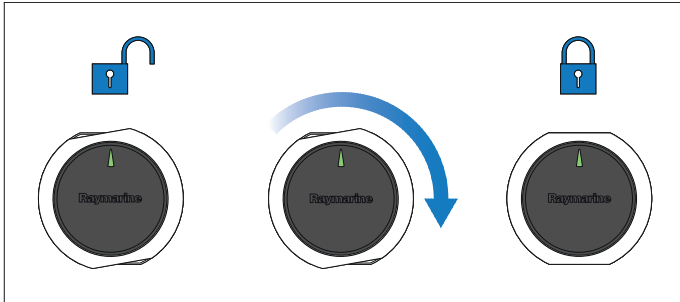

Twist the screwdriver 90°, so that there is a small gap between the mounting trim and mounting tray.

Important:

To help prevent scratching the product, cover the tip of your screwdriver with a small piece of insulation tape.

- With the screwdriver in place, twist the mounting trim counter-clockwise approximately 10°, and then lift away from the product.

8.6 Releasing the product from the bracket

Follow the steps below to release the product from the mounting bracket.

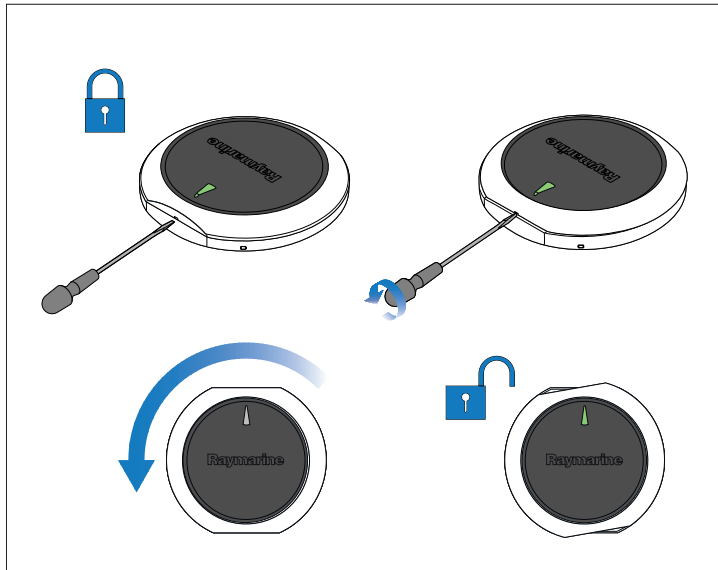

- Insert the end of a small flat blade screwdriver (or similar tool) into the release hole located on the flat edge of the mounting bracket.

CHAPTER 9: CABLES AND CONNECTIONS — GENERAL INFORMATION

CHAPTER CONTENTS

- [9.1 General cabling guidance — page 40](#)

9.1 General cabling guidance

Cable types and length

It is important to use cables of the appropriate type and length.

- Unless otherwise stated only use cables supplied by Raymarine.
- Where it is necessary to use non-Raymarine cables, ensure that they are of correct quality and gauge for their intended purpose. (e.g.: longer power cable runs may require larger wire gauges to minimize voltage drop along the run).

Cable routing and bend radius

To maximize cable performance and lifespan, it's important to ensure that all cables are routed correctly and adequate space is provided to allow for each cable's minimum bend radius.

Minimum cable bend radius

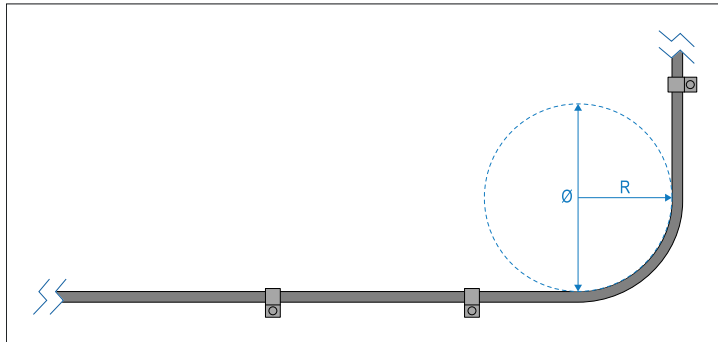

Do NOT bend cables excessively. Wherever possible, ensure that your chosen product installation location allows enough clearance for the minimum cable bend diameter specified in the following table:

	Description	Value
Ø	Cable minimum bend diameter .	200 mm (7.87 in.)
R	Cable minimum bend radius .	100 mm (3.94 in.)

Note:

For products where multiple different cable types are connected, each with a different minimum cable bend radius, the higher figure is provided in the table above (i.e. the cable with the greatest minimum bend radius is specified).

Cable routing — best practices

- Protect all cables from physical damage and exposure to heat. Use trunking or conduit where possible. Do NOT run cables through bilges or doorways, or close to moving or hot objects.
- Secure cables in place using cable clips or cable ties. Coil any excess cable and tie it out of the way.
- Where a cable passes through an exposed bulkhead or deckhead, use a suitable watertight feed-through (conduit).
- Do NOT run cables near to engines or fluorescent lights.
- Always route data cables as far away as possible from:
 - Other equipment and cables.
 - High current-carrying AC and DC power lines.
 - Antennas.

Strain relief

Use adequate strain relief for cabling to ensure that connectors are protected from strain and will not pull out under extreme sea conditions.

Cable shielding

Ensure that cable shielding is not damaged during installation and that all cables are properly shielded.

Important:

Be aware that some **third-party** cables and adapters (for example, certain Ethernet cables using RJ45 connectors) are not always shielded. To prevent breaks in cable shielding continuity and potential grounding issues, special attention is required to ensure that any cables, extension cables, adapters, or other signal-coupling devices used in cable runs **maintain all shield connections throughout the cable run**.

Suppression ferrites

- Raymarine cables may be pre-fitted or supplied with suppression ferrites. These are important for correct EMC performance. If ferrites are supplied separately to the cables (i.e. not pre-fitted), you must fit the supplied ferrites, using the supplied instructions.
- If a ferrite has to be removed for any purpose (e.g. installation or maintenance), it must be replaced in the original position before the product is used.
- Use only ferrites of the correct type, supplied by Raymarine or its authorized dealers.
- Where an installation requires multiple ferrites to be added to a cable, additional cable clips should be used to prevent stress on the connectors due to the extra weight of the cable.



Warning: Positive ground systems

Do NOT connect this unit to a system which has positive grounding.

CHAPTER 10: NETWORK CONNECTIONS

CHAPTER CONTENTS

- 10.1 Connections overview — page 43
- 10.2 Connecting SeaTalk NG cables — page 43
- 10.3 Evolution-Series minimum system example (ACU-100 / ACU-150) — page 43
- 10.4 Evolution-Series recommended system example (ACU-100 / ACU-150) — page 44
- 10.5 Evolution-Series minimum system example (ACU-200 / ACU-400) — page 45
- 10.6 Evolution-Series recommended system example (ACU-200 / ACU-300 / ACU-400) — page 46

10.1 Connections overview

The EV-1 contains the following connectors:

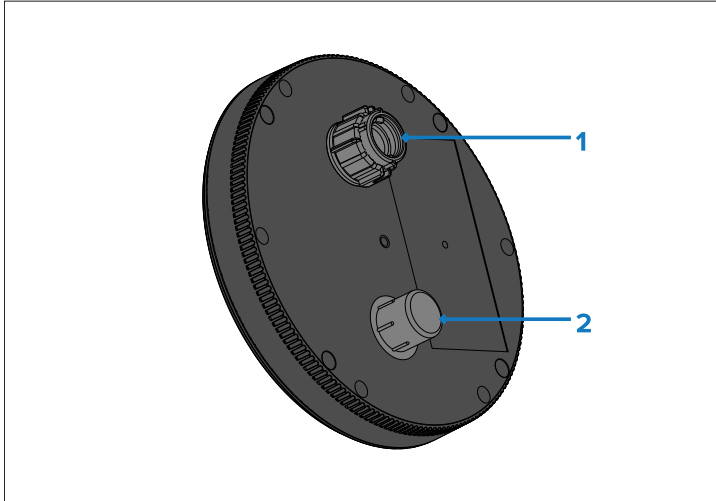

1. SeaTalk NG
2. DeviceNet⁽¹⁾

Important:

(1) The DeviceNet connection is not currently supported.

10.2 Connecting SeaTalk NG cables

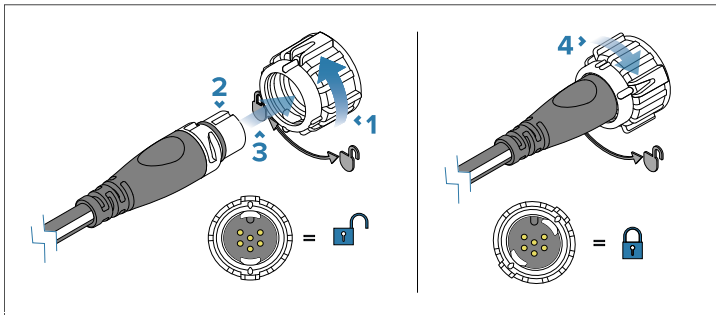

1. Rotate your product's SeaTalk NG connector locking collar counter clockwise, so that the connector is in the unlocked position.
2. Ensure the cable's connector is correctly oriented (groove pointing up).
3. Fully insert the cable connector.
4. Rotate the locking collar clockwise (2 clicks) until it is in the locked position.

10.3 Evolution-Series minimum system example (ACU-100 / ACU-150)

The following example provides an overview of an Evolution-Series *minimum system*, including the available connections and types of devices that **must** be connected to your Evolution-Series system when an ACU-100 or ACU-150 is present.

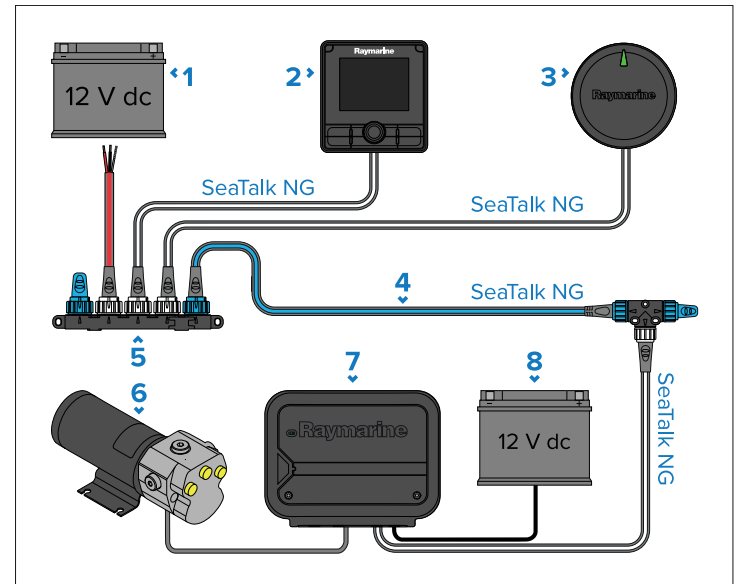

Note:

A rudder angle reference sensor / transducer is a highly recommended system component (not shown in the drawing above, but available separately as M81105).

1. 12 V dc power supply (providing power to the SeaTalk NG backbone).
2. Autopilot controller (p70Rs shown).
3. EV-1 sensor.
4. SeaTalk NG backbone.
5. SeaTalk NG 5-way block.
6. Drive unit (hydraulic pump shown).
7. ACU-100 / ACU-150.
8. 12 V dc power supply (providing power to the ACU-100 / ACU-150).

10.4 Evolution-Series recommended system example (ACU-100 / ACU-150)

The following example provides an overview of a *recommended system*, including the available connections and types of devices that can be connected to your system when an ACU-100 or ACU-150 is present.

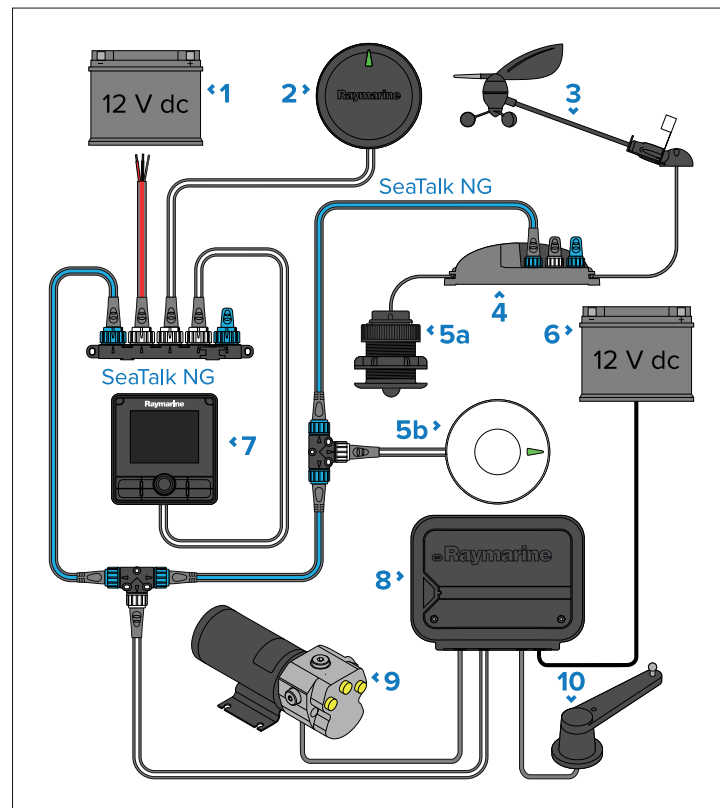

1. 12 V dc power supply (providing power to SeaTalk NG backbone).
2. EV-1 sensor.
3. Wind transducer (only required for Sailing vessels).
4. iTC-5 converter.

5. Speed data source:
 - a. Speed transducer (providing STW data), or
 - b. GNSS (GPS) Receiver (providing SOG data).
6. 12 V dc power supply (providing power to the ACU-100 / ACU-150).
7. Autopilot controller (p70Rs shown).
8. ACU-100 / ACU-150.
9. Drive unit (hydraulic pump shown).
10. Rudder angle reference sensor / transducer (M81105).

10.5 Evolution-Series minimum system example (ACU-200 / ACU-400)

The following example provides an overview of an Evolution-Series *minimum system*, including the available connections and types of devices that **must** be connected to your Evolution-Series system when an ACU-200 or ACU-400 is present.

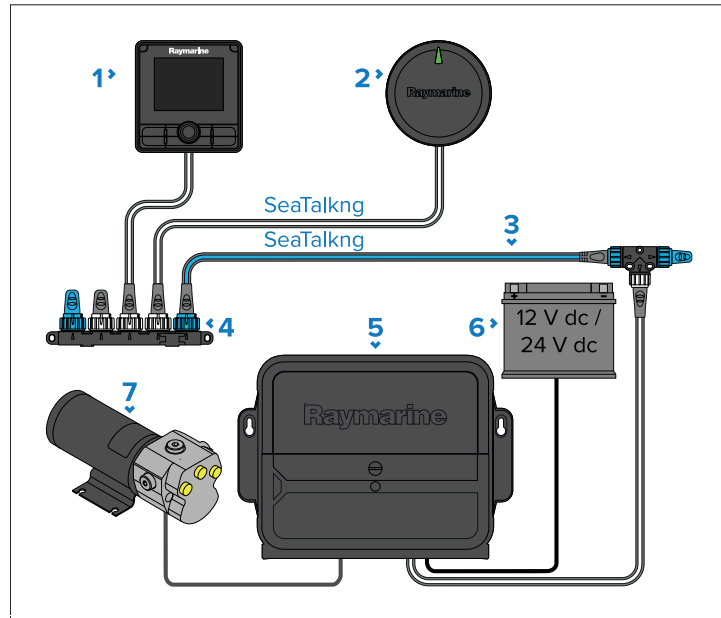

Note:

A rudder angle reference sensor / transducer is a highly recommended system component (not shown in the drawing above, but available separately as M81105).

1. Autopilot controller (e.g. p70Rs).
2. EV-1 sensor.
3. SeaTalk NG backbone.
4. SeaTalk NG 5-way block.
5. ACU-200 / ACU-400.
6. 12 V / 24 V dc power supply (providing power to the ACU-200 / ACU-400 and SeaTalk NG backbone).
7. Drive unit (e.g. hydraulic pump).

10.6 Evolution-Series recommended system example (ACU-200 / ACU-300 / ACU-400)

The following example provides an overview of an Evolution-Series *recommended system*, including the available connections and types of devices that can be connected to your autopilot system when an ACU-200 or ACU-400 is present, which **must** be connected to your Evolution-Series system when an ACU-300 is present.

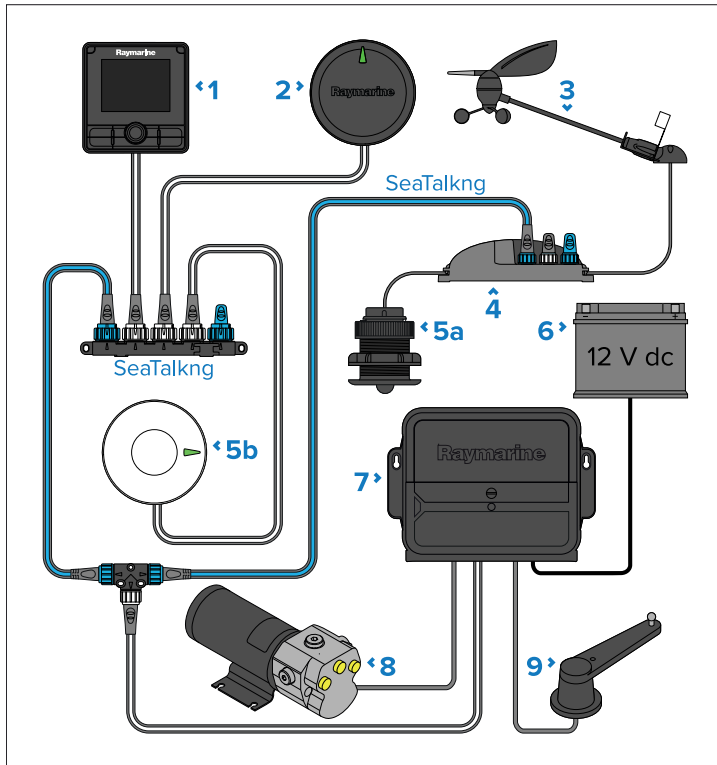

1. Autopilot controller (e.g. p70Rs).
2. EV-1 sensor.
3. Wind transducer (only required for Sailing vessels).

4. iTC-5 converter.
5. Speed data source:
 - a. Speed transducer (providing STW data), or
 - b. GNSS (GPS) Receiver (providing SOG data).
6. 12 V / 24 V dc power supply (providing power to the ACU and SeaTalk NG backbone).
7. ACU-200 / ACU-300 / ACU-400.
8. Drive unit (e.g. hydraulic pump).
9. Rudder angle reference sensor / transducer (M81105) — This is **essential for ACU-300** systems, and highly recommended for all other systems.

CHAPTER 11: PILOT CONTROLLER CONNECTIONS

CHAPTER CONTENTS

- [11.1 SeaTalk NG pilot controller connection — page 48](#)
- [11.2 SeaTalk 1 pilot controller connection — page 48](#)

11.1 SeaTalk NG pilot controller connection

A SeaTalk NG pilot controller is connected directly into the same SeaTalk NG backbone as the Evolution-Series autopilot.

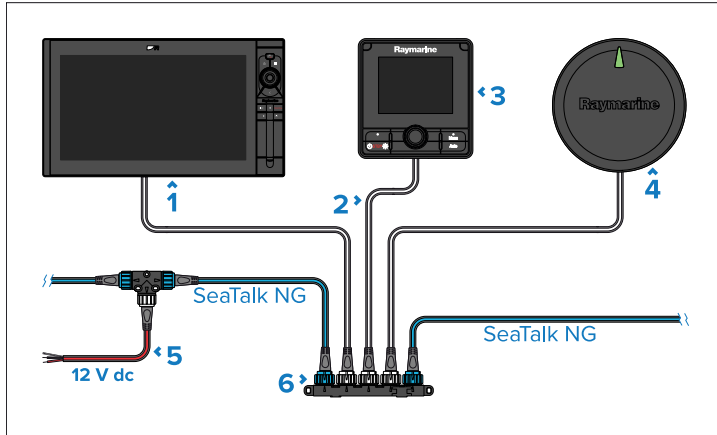

1. SeaTalk NG MFD (MFDs require a separate power supply).
2. SeaTalk NG spur cable.
3. SeaTalk NG pilot controller (powered from the SeaTalk NG backbone).
4. SeaTalk NG autopilot.
5. SeaTalk NG 12 V dc power supply connection.
6. SeaTalk NG 5-way block.

11.2 SeaTalk 1 pilot controller connection

The SeaTalk 1 to SeaTalk NG converter can be used to enable control of SeaTalk NG autopilots using legacy SeaTalk 1 pilot controllers. Other SeaTalk 1 devices can be connected to the SeaTalk NG backbone in the same way.

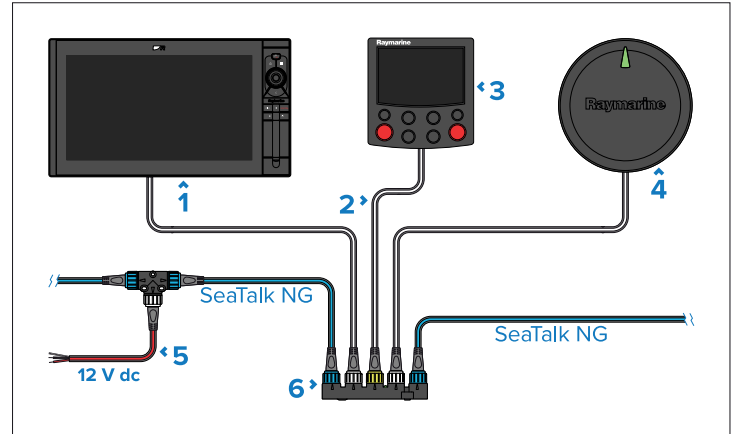

1. SeaTalk NG MFD (MFDs require a separate power supply).
2. SeaTalk 1 to SeaTalk NG adaptor cable (A22164).
3. SeaTalk 1 pilot controller (powered from the SeaTalk NG backbone).
4. SeaTalk NG autopilot.
5. SeaTalk NG 12 V dc power supply connection.
6. SeaTalk 1 to SeaTalk NG converter (E22158).

CHAPTER 12: POWER CONNECTIONS

CHAPTER CONTENTS

- 12.1 SeaTalk NG power supply — page 50
- 12.2 Power connection via Autopilot Control Unit (ACU-Series) — page 50
- 12.3 Inline fuse requirement — page 50
- 12.4 Inline fuse and thermal breaker ratings — page 51
- 12.5 12 Volt dc only — page 51
- 12.6 SeaTalk NG power cables — page 51
- 12.7 SeaTalk NG power cable extension — page 52
- 12.8 SeaTalk NG product loading — page 52
- 12.9 SeaTalk NG power connection point — page 52
- 12.10 SeaTalk NG system loading — page 53
- 12.11 Power distribution — SeaTalk NG — page 53
- 12.12 12 Volt dc only — page 55
- 12.13 Positive ground systems — page 55
- 12.14 Product grounding — page 56

12.1 SeaTalk NG power supply

Your product is supplied power via the SeaTalk NG backbone (or the NMEA 2000 backbone if applicable).

A SeaTalk NG backbone requires a single 12 V dc power supply. Power can be supplied to the SeaTalk NG backbone by one of the following methods:

- (1) Direct connection to a 12 V dc battery using an inline 5 amp fuse.
- Connection to a 12 V dc distribution panel using a 3 amp thermal breaker.
- (2) Connection to the SeaTalk NG connector of an ACU-Series Autopilot Control Unit (not ACU-100 or ACU-150), or an SPX-Series course computer (not SPX-5).
- For 24 V vessels, connection must be via a 5 amp, regulated, continuous 24 V dc to 12 V dc converter.

Note:

- (1) The battery used for starting the vessel's engine(s) should NOT be used to power the SeaTalk NG backbone, as this can cause sudden voltage drops when the engines are started.
- (2) The ACU-100, ACU-150 or SPX-5 cannot be used to power the SeaTalk NG backbone.
- The course computer SeaTalk NG connector includes a power switch that must be in the On position to provide power to the backbone.

12.2 Power connection via Autopilot Control Unit (ACU-Series)

The SeaTalk NG backbone can be supplied 12 V dc power from a compatible Raymarine Autopilot Control Unit (ACU-Series).

Important:

The SeaTalk NG backbone must have a single power supply connection. If your SeaTalk NG backbone is supplied power directly from a battery or distribution panel, then you must ensure that the SeaTalk NG power switch on your ACU-Series is switched Off.

Note:

ACU-100, ACU-150 and SPX-5 autopilot control units cannot supply power to the SeaTalk NG backbone.

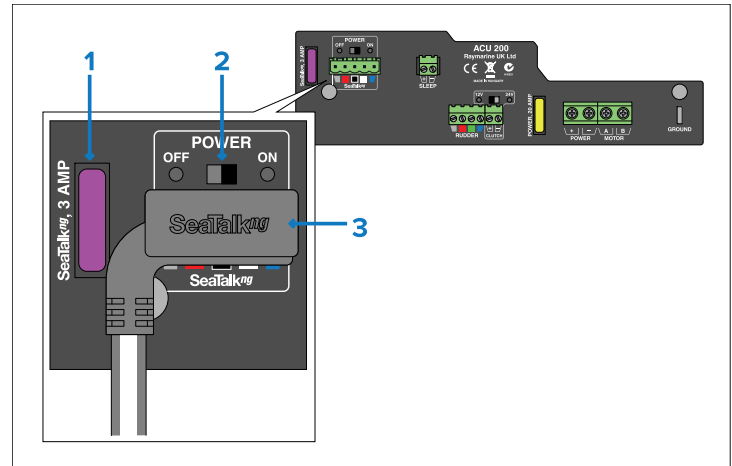

1. Fuse for SeaTalk NG power supply.
2. Power switch for SeaTalk NG power supply:
 - a. Select the [OFF] position if your SeaTalk NG backbone is supplied power directly from a battery or distribution panel.
 - b. Select the [ON] position if your SeaTalk NG backbone is supplied power by the ACU-Series.
3. ACU-Series/SPX-Series autopilot to SeaTalk NG spur cable (part number: R12112).

12.3 Inline fuse requirement

If your product is NOT supplied with an inline fuse (whether separately or fitted to the power cable), you MUST fit a suitably-rated inline fuse to your product's red power wire, housed in a waterproof fuse holder.

The illustration below shows the two main types of inline fuse with waterproof holder, for use in marine electronics installations. Fuses in a variety of ratings are widely available at chandleries and marine electrical retailers.

Select one of the following fuse types to protect your product:

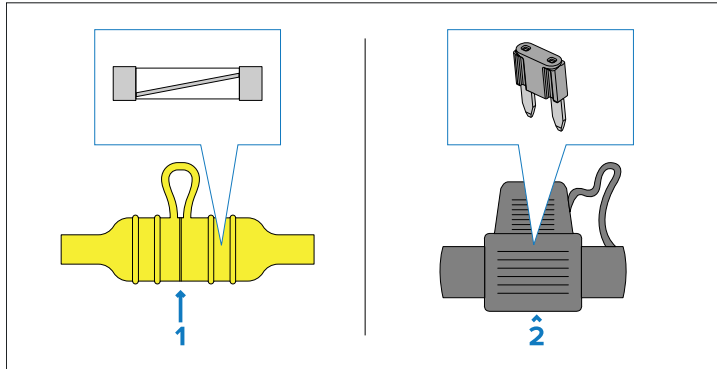

1. Waterproof fuse holder containing a “glass”-type inline fuse.
2. Waterproof fuse holder containing a “blade”-type inline fuse.

Fuse ratings:

- *Voltage rating* — must be equal to or greater than the voltage of your vessel’s power supply.
- *Current rating* — refer to the *Inline fuse and thermal breaker rating* section in this document.

12.4 Inline fuse and thermal breaker ratings

The SeaTalk NG network’s power supply requires a suitably-rated inline fuse or thermal breaker to be fitted.

Inline fuse rating	Thermal breaker rating
5A	3A (refer to note below)

Note:

The suitable fuse rating for the thermal breaker is dependent on:

1. How many devices you have connected to your SeaTalk NG network, and;
2. How many devices are sharing the same thermal breaker that your SeaTalk NG network is connected to.

12.5 12 Volt dc only

This product must ONLY be connected to a 12 V dc power source.

12.6 SeaTalk NG power cables

The following SeaTalk NG power cables can be used to connect the backbone to your chosen **12 V dc** power supply:

Direct connection cables

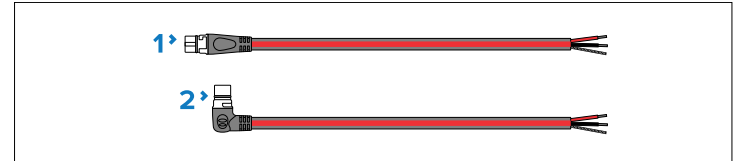

1. Standard (straight) SeaTalk NG power cable, 2 m (6.6 ft) (part number: **A06049**).
2. Elbow (right-angled) SeaTalk NG power cable, 2 m (6.6 ft) (part number: **A06070**).

Wiring

- **+ Red (positive) wire** — connects to the battery or distribution panel positive terminal. A waterproof fuse holder with 5 A inline fuse (not supplied) must be fitted to this red wire.
- **– Black (negative) wire** — connects to battery or distribution panel negative terminal.
- **Drain wire** — connects to the vessel’s RF common ground point (if available), or the battery’s negative (-) terminal.

Autopilot Control Unit connection cable

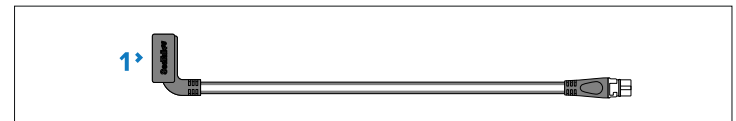

1. ACU-Series/SPX-Series autopilot to SeaTalk NG spur cable, 0.3 m (1.0 ft) (part number **R12112**). Connects the course computer to the SeaTalk NG backbone. This connection can also be used to provide 12 V dc power to the SeaTalk NG backbone.

12.7 SeaTalk NG power cable extension

If you need to extend the length of the SeaTalk NG power cable, ensure you observe the following advice:

- Ensure that any extensions of the SeaTalk NG power cable are of a sufficient gauge for the supply voltage, the total current load of the device, and the length of the cable run — as the cable run length increases, the greater the voltage drop will be from one end of the power cable to the other.
- Refer to the following table for typical **minimum** power cable wire gauges:

Cable length in meters (feet)	Wire gauge in AWG (mm ²) for 12 V supply
<8 (<25)	16 (1.31 mm ²)
16 (50)	14 (2.08 mm ²)
24 (75)	12 (3.31 mm ²)
>32 (>100)	10 (5.26 mm ²)

Important:

Be aware that some products in your system (such as sonar modules) can create voltage peaks at certain times, which may impact the voltage available to other products during the peaks.

Important:

To ensure power cables (including any extension) are of a sufficient gauge, ensure that there is a continuous **minimum** voltage of **10.8 V dc** at the end of the SeaTalk NG power cable where it enters the SeaTalk NG backbone, even with a fully flat battery at 11 V dc. (Do not assume that a flat battery is at 0 V dc. Due to the discharge profile and internal chemistry of batteries, the current drops much faster than the voltage. A “fully flat” battery still shows a positive voltage, even if it doesn’t have enough current to power your device.)

12.8 SeaTalk NG product loading

The number of products that can be connected to a SeaTalk NG backbone depends on the current draw of each product and the physical length of the backbone cabling.

NMEA 2000 Load Equivalency Numbers (LEN) are used to express the amount of current that is drawn from SeaTalk NG products (**1 LEN = 50 mA**). The LEN for each product can be found in the product’s *Technical Specification*.

Products which have a dedicated power supply connection and are connected to the SeaTalk NG backbone will still have an LEN rating. This is because the product’s NMEA 2000 / SeaTalk NG internal transceiver will still be powered by the SeaTalk NG backbone.

LENs are used to determine the power connection point for the SeaTalk NG backbone.

12.9 SeaTalk NG power connection point

The point along the backbone where the power connection should be made is based on the length of the backbone.

Note:

- A 12 V dc power supply must be connected to a *white* spur SeaTalk NG connection on the backbone.
- Do NOT connect the power connection to a *blue* SeaTalk NG backbone connector.
- **With the exception of** the iTC-5 and the backbone itself, do NOT connect the power supply directly to a product’s *white* SeaTalk NG spur connector.

Small systems

If the backbone length is 60 m (197 ft) or less, the power connection may be made at any point in the backbone.

Large systems

If the backbone length is greater than 60 m (197 ft), the power connection should be made at a point that creates a balanced current draw from each side of the backbone. Load Equivalency Numbers (LEN) are used to determine the power connection point for the system.

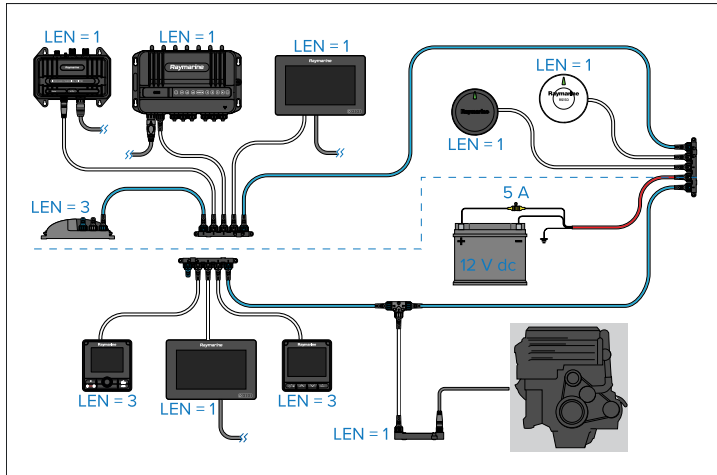

In the example above, the system has an overall LEN of 16, so the optimum connection point would be to have a loading of 8 LEN either side of the connection point.

12.10 SeaTalk NG system loading

The maximum loading (LEN) for a SeaTalk NG system depends on the length of the backbone.

Unbalanced system loading:

- **Backbone Length:** 0 m (0 ft) to 20 m (66 ft) — **Maximum LEN:** 40
- **Backbone Length:** > 20 m (66 ft) to 40 m (131 ft) — **Maximum LEN:** 20
- **Backbone Length:** > 40 m (131 ft) to 60 m (197 ft) — **Maximum LEN:** 14

Balanced system loading:

- **Backbone Length:** 0 m (0 ft) to 60 m (197 ft) — **Maximum LEN:** 100
- **Backbone Length:** > 60 m (197 ft) to 80 m (262 ft) — **Maximum LEN:** 84
- **Backbone Length:** > 80 m (262 ft) to 100 m (328 ft) — **Maximum LEN:** 60
- **Backbone Length:** > 100 m (328 ft) to 120 m (394 ft) — **Maximum LEN:** 50

- **Backbone Length:** > 120 m (394 ft) to 160 m (525 ft) — **Maximum LEN:** 40
- **Backbone Length:** > 160 m (525 ft) to 200 m (656 ft) — **Maximum LEN:** 32

12.11 Power distribution — SeaTalk NG

Recommendations and best practice.

- Only use approved SeaTalk NG power cables. Do NOT use a power cable designed for, or supplied with, a different product.
- See below for more information on implementation for some common power distribution scenarios.

Important:

- When planning and wiring, take into consideration other products in your system, some of which (e.g. sonar modules) may place large power demand peaks on the vessel's electrical system, which may impact the voltage available to other products during the peaks.
- The information provided below is for guidance only, to help protect your product. It covers common vessel power arrangements, but does NOT cover every scenario. If you are unsure how to provide the correct level of protection, please consult an authorized Raymarine dealer or a suitably qualified professional marine electrician.

Implementation — connection to distribution panel (recommended)

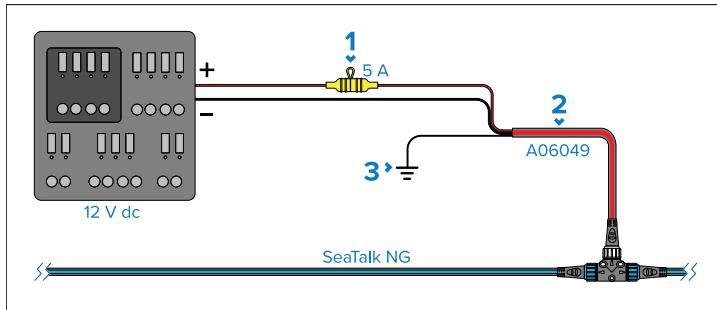

1. Waterproof fuse holder with 5 A inline fuse must be fitted (not supplied).
 2. SeaTalk NG power cable.
 3. RF Ground connection point for drain wire.
- Ideally, the SeaTalk NG power cable should be connected to a suitable breaker or switch on the vessel's distribution panel or factory-fitted power distribution point. It is recommended that a 5 A inline fuse is fitted to the red (positive) wire of the SeaTalk NG power cable.
 - The distribution point should be fed from the vessel's primary power source by 8 AWG (8.36 mm²) cable.
 - Ideally, all equipment should be wired to individual suitably-rated thermal breakers or fuses, with appropriate circuit protection. Where this is not possible and more than one item of equipment shares a breaker, use individual in-line fuses for each power circuit to provide the necessary protection.

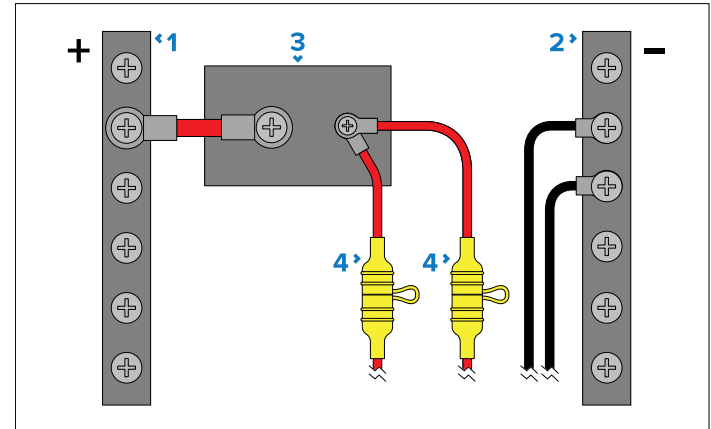

1. Positive (+) bar
2. Negative (-) bar
3. Circuit breaker
4. Waterproof fuse holder with 5 A inline fuse must be fitted (not supplied).

Important:

Observe the recommended fuse / breaker ratings provided in the product's documentation, however be aware that the suitable fuse / breaker rating is dependent on the number of devices being connected.

Implementation — direct connection to battery

- Where connection to a power distribution panel is not possible, the power cable may be connected to the vessel's battery.
- You **MUST** fit a 5 A inline fuse between the red wire and the battery's positive terminal.
- If you need to extend the length of the power cable, ensure you use suitably rated cable and that sufficient power (12 V dc) is available at the SeaTalk NG backbone's power connection.

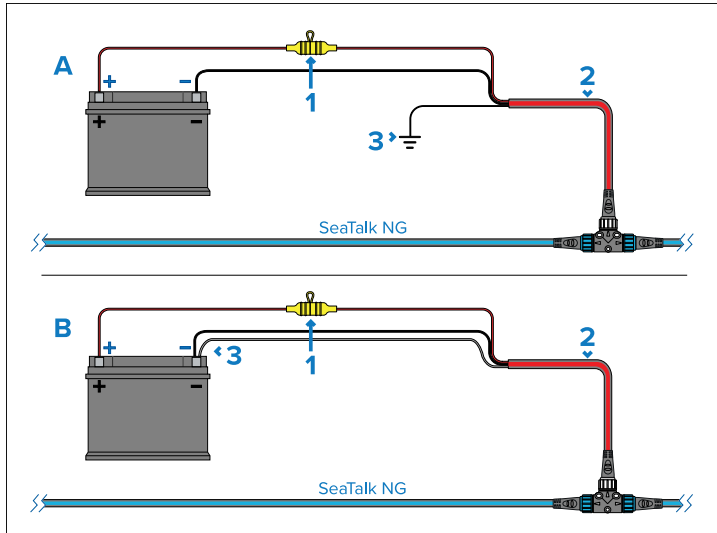

1. Waterproof fuse holder with 5 A inline fuse must be fitted (not supplied).
2. SeaTalk NG power cable.
3. Connection point for drain wire.

Battery connection scenario A:

Suitable for a vessel with a common RF ground point. In this scenario, the power cable's drain wire should be connected to the vessel's common RF ground point.

Battery connection scenario B:

Suitable for a vessel without a common RF ground point. In this scenario the power cable's drain wire should be connected directly to the battery's negative terminal.

SeaTalk NG Power cable extension

If you need to extend the length of the SeaTalk NG power cable, ensure you use suitably-rated cable, and that sufficient power is available at the SeaTalk NG backbone's power connection point:

- For power cable extensions, a **minimum** wire gauge of 16 AWG (1.31 mm²) is recommended. For cable runs longer than 15 m (49.2 ft), you may need to consider a thicker wire gauge (e.g. 14 AWG (2.08 mm²), or 12 AWG (3.31 mm²).

- To ensure power cables (including any extension) are of a sufficient gauge, ensure that there is a continuous **minimum** voltage of **10.8 V dc** at the end of the cable where it enters the product's power connector, even with a fully flat battery at 11 V dc. (Do not assume that a flat battery is at 0 V dc. Due to the discharge profile and internal chemistry of batteries, the current drops much faster than the voltage. A "fully flat" battery still shows a positive voltage, even if it doesn't have enough current to power your device.)

Important:

Be aware that some products in your system (such as sonar modules) can create voltage peaks at certain times, which may impact the voltage available to other products during the peaks.

More information

It is recommended that best practice is observed in all vessel electrical installations, as detailed in the following standards:

- BMEA Code of Practice for Electrical and Electronic Installations in Boats
- NMEA 0400 Installation Standard
- ISO 13297: Small craft — Electrical systems — Alternating and direct current installations
- ISO 10133: Small craft — Electrical systems — Extra-low-voltage d.c. installations
- ABYC E-11 AC & DC Electrical Systems on Boats
- ABYC A-31 Battery chargers and Inverters
- ABYC TE-4 Lightning Protection

12.12 12 Volt dc only

This product must **ONLY** be connected to a 12 V dc power source.

12.13 Positive ground systems

Do **NOT** connect this unit to a system which has positive grounding.

12.14 Product grounding

Important safety information for connections to ground.

Before applying power to this product, it **MUST** be correctly grounded, in accordance with the instructions provided.

CHAPTER 13: SYSTEM CHECKS

CHAPTER CONTENTS

- 13.1 Post-installation checks — page 58
- 13.2 Autopilot system setup — page 58
- 13.3 Rudder damping levels and deadband angles — page 58

13.1 Post-installation checks

These checks should be carried out after installation, and prior to the commissioning of the autopilot system.

1. Switch on power to the autopilot system and any associated equipment.
 - ACU-Series unit.
 - Autopilot controller.
 - SeaTalk NG backbone (if this has its own power supply).
2. Check to ensure that the autopilot controller powers up. If the display is blank, press and hold the [Power] button for 2 seconds.
3. Check to ensure that the EV-1, ACU-Series unit and autopilot controller have the latest software installed. For more information, visit: <https://bit.ly/rym-software>
4. Check the display for error messages that could indicate a problem with the installation.
5. Check the LED status indications for the EV-1. For more information, refer to: [p.62 — LED indications](#)
6. If the fault persists and cannot be rectified, **contact your dealer or Raymarine product support.**

13.2 Autopilot system setup

Important:

Before using the autopilot system it is essential that it is properly commissioned in accordance with the setup instructions.

1. Perform an initial power-on test to ensure all components are working correctly.
2. Refer to the latest version of your compatible Autopilot Controller's user documentation for detailed instructions on how to commission your Evolution-Series autopilot system.

13.3 Rudder damping levels and deadband angles

For autopilot systems which include a rudder angle reference sensor / transducer, rudder damping is used to prevent Evolution-Series autopilot system over-activity, characterized by

“hunting” maneuvers. A number of rudder damping levels are available to address this behavior. Rudder damping levels relate to “deadband angles”, and can be configured using your autopilot control head (e.g. p70s/p70Rs or MFD). A higher damping level is intended to eliminate pilot and helm over-activity.

Typically, the appropriate rudder damping level is the lowest acceptable value. However, it is important to be aware that the rudder damping scaling has been changed in recent versions of the ACU-Series units, which include newer processor and software versions (these units can be identified with an “A” appended to their SKU).

Important:

The rudder damping levels can have a significant impact on your autopilot performance. If you are unsure as to how to adjust these settings to best suit your autopilot system, please refer to your dealer or Raymarine product support.

The following table lists the rudder damping levels and deadband angles that are available with both old and new versions of the ACU-Series software:

Rudder damping level	Existing Deadband angle (ACU-100, ACU-150, ACU-200, ACU-400)	Existing Deadband angle (ACU-300)	New Deadband angle (ACU-Series software version v3.11 or later)
1	0.1°	0.15°	0.1°
2	0.2°	0.30°	0.2°
3	0.3°	0.45°	0.3°
4	0.4°	0.60°	0.4°
5	0.5°	0.75°	0.7°
6	0.6°	0.9°	0.9°
7	0.7°	1.05°	1.1°
8	0.8°	1.20°	1.6°
9	0.9°	1.35°	2.2°

It's important to check the rudder damping level currently configured on your autopilot control head, to ensure it matches your needs. The rudder damping value should be increased one level at a time until the autopilot stops hunting.

Rudder Damping level adjustments

You can adjust the Rudder Damping levels using your pilot control head.

The menu item for adjusting the Rudder Damping level depends on which pilot controller you are using:

- **p70 / p70s / p70R / p70Rs** — *[Menu > Set-up > Autopilot Calibration > Drive Settings > Rudder Damping].*
- **LightHouse 3 MFD** — *[Homescreen > Settings > Autopilot > Pilot control > Advanced settings > Rudder Damping].*
- **LightHouse 2 MFD** — From the Pilot Set-up page: *[Pilot Settings > Drive Settings > Rudder Damping]*

CHAPTER 14: TROUBLESHOOTING AND ALARMS

CHAPTER CONTENTS

- 14.1 LED diagnostic guidance — page 61
- 14.2 LED indications — page 62
- 14.3 Error message troubleshooting — page 63
- 14.4 Miscellaneous troubleshooting — page 66
- 14.5 Alarms — page 66

14.1 LED diagnostic guidance

Your product has diagnostic LEDs which can be used to identify the unit's status and to help troubleshoot any potential issues that may occur.

The following section provides two basic examples of how to interpret the LED diagnostic patterns included in this publication.

Example solid LED diagnostic pattern:

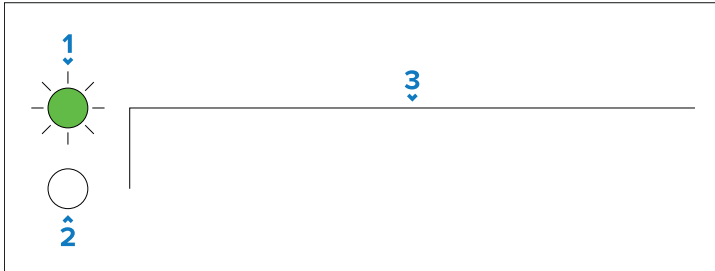

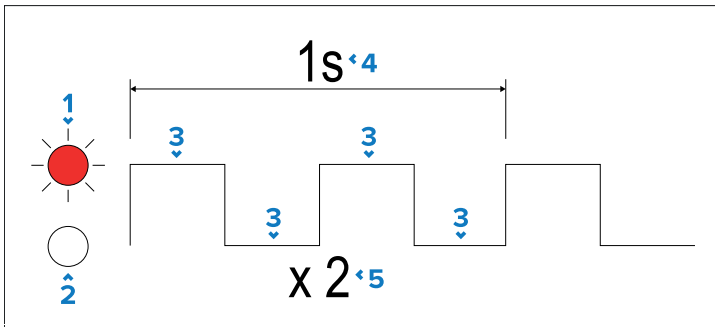

1. **LED ON** — Indicates the color assigned to the unit's diagnostic LED, and confirms that the diagnostic LED is active (switched **on**).
2. **LED OFF** — Indicates that the unit's diagnostic LED is inactive (switched **off**).
3. **Diagnostic pattern** — Indicates a diagnostic pattern based on the number and duration of *peaks* (indicating LED is switched **on**) and *troughs* (indicating LED is switched **off**) generated within the duration of the diagnostic pattern. In the example shown above, a continuous peak occurs, indicating that the LED is permanently **on**.

Example flashing LED diagnostic pattern:



1. **LED ON** — Indicates the color assigned to the unit's diagnostic LED, and confirms that the diagnostic LED is active (switched **on**).
2. **LED OFF** — Indicates that the unit's diagnostic LED is inactive (switched **off**).
3. **Diagnostic pattern** — Indicates a diagnostic pattern based on the number and duration of *peaks* (indicating LED is switched **on**) and *troughs* (indicating LED is switched **off**) generated within the duration of the diagnostic pattern. In the example shown above, a peak followed by a trough occurs and then repeats again, indicating that the LED flashes twice within a period of one second.
4. **Diagnostic pattern duration** — Indicates the total duration of the diagnostic pattern.
5. **Diagnostic pattern flash total** — Indicates the total number of flashes that occur within the diagnostic pattern.

14.2 LED indications

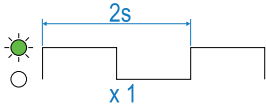
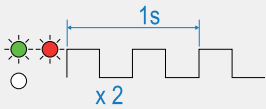
LED Indication	LED Status and required action
	<p>(No color) LED has been disabled</p> <ul style="list-style-type: none"> Ensure that the <i>[Always off]</i> multifunction display / chartplotter LED setting has not been enabled (requires LightHouse 4 software version v4.6.74 or later). For more information, refer to: p.62 — Switching off sensor LEDs
	<p>(Solid green) LED Normal operation</p> <ul style="list-style-type: none"> None (normal power up takes <1 minute).
	<p>(Green) Unit is initializing; no pilot or compass functions currently available</p> <ul style="list-style-type: none"> None (normal power up takes <1 minute).
	<p>(Green and Red) LED has been triggered manually</p> <ul style="list-style-type: none"> Ensure that the <i>[Find me]</i> multifunction display / chartplotter LED setting has not been enabled (requires LightHouse 4 software version v4.6.74 or later). Once enabled, the LED indicator shown will appear for a 5 minute duration. For more information, refer to: p.62 — Switching off sensor LEDs

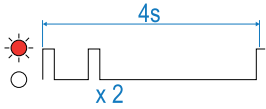
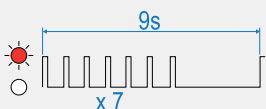
LED Indication	LED Status and required action
	<p>(Red) No SeaTalk NG connection</p> <ul style="list-style-type: none"> Ensure network is powered. Ensure network cable and connections are secure and free from damage. If problem persists contact Raymarine technical support.
	<p>(Red) SeaTalk NG connected but not receiving data</p> <ul style="list-style-type: none"> If problem persists contact Raymarine technical support.

Switching off sensor LEDs

To assist users who wish their vessel to “go dark” (i.e. not emit any visible light), the LED indicators present on SeaTalk NG position sensors can be switched off. Supported devices: RS150, EV-1, EV-2 and AR200).

Note:

The *[Always Off]* feature may not be available for devices running older software versions. Ensure that you obtain the latest available software for your position sensors.

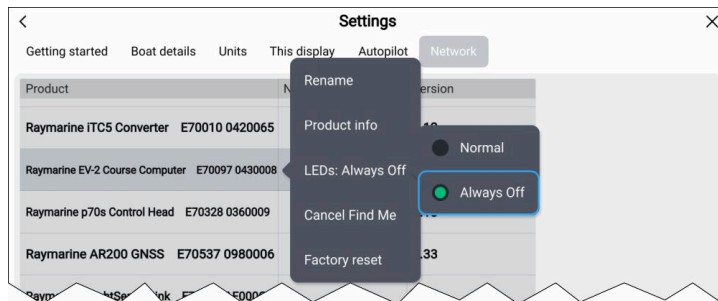

1. Open the *[Network]* settings menu: *[Homescreen > Settings > Network]*.
2. Select the relevant sensor from the network list.

3. Select *[LEDs:]*.
4. Select *[Always Off]*.

The status LED on the selected device will now be switched off, and will remain off until this setting is reverted to *[Normal]*, or the *[Find Me]* feature is enabled.

Find me

The *[Find me]* feature assists you in finding the physical installation location of a specific Raymarine SeaTalk NG position sensor (i.e.: RS150, EV-1, EV-2, or AR200).

The *[Find me]* feature works by making the selected device's status LED flash continuously for 5 minutes, giving you time to search the vessel to determine the device's physical location. The feature works even if the device's LEDs have been switched to *[Always off]*.

The *[Find Me]* flash sequence will be visibly different than normal LED status sequences in that both the red and green LEDs will flash on and off at the same time, twice every second for 5 minutes.

Note:

The *[Find me]* feature may not be available on devices running older software versions. Ensure that you obtain the latest available software for your position sensors.

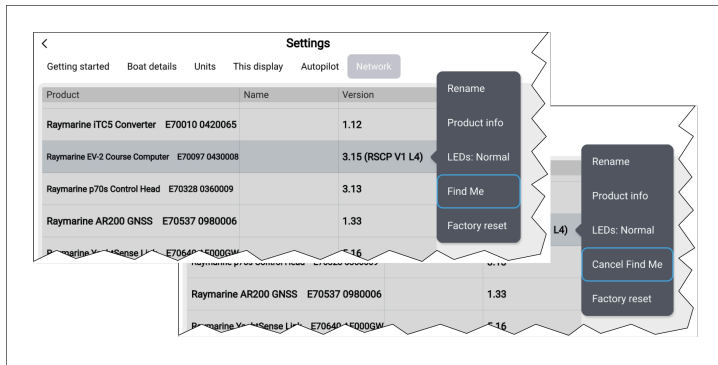

To initiate the *[Find Me]* feature for a specific SeaTalk NG device, locate the device name in the *[Network]* settings menu, and then select *[Find Me]* from the device's pop-over menu.

Once *[Find Me]* has been activated, its menu option will change to *[Cancel Find Me]* until 5 minutes has elapsed.

Selecting *[Cancel Find Me]* at any time within the 5 minute timeframe will stop the LED flashing and return the device to its previous LED state.

14.3 Error message troubleshooting

The following alarm messages are displayed on the Autopilot controller display when there is an error with the autopilot system requiring your attention. Use the information provided in this section to troubleshoot your autopilot.

Error: AUTO RELEASE

Possible causes

Possible fault with rudder angle reference sensor. Alternatively, if your autopilot system includes a stern I/O drive, you have taken manual control of the steering while the pilot is in Auto mode.

Possible solutions

- Check rudder angle reference sensor connections.

Error: DRIVE STOPPED

Possible causes

- Motor / steering has not moved within 20 seconds of a course change command.
- The autopilot is unable to turn the rudder (either because the weather load on the helm is too high, or if the rudder angle sensor has passed beyond the preset rudder limits or rudder end-stops).
- Autopilot resets due to an external event (such as use of the sleep switch, or faulty wiring causing the autopilot components to power cycle).
- Autopilot resets due to software error.

Possible solutions

- Check the rudder angle reference sensor has been installed correctly to reflect the limits and end-stops of the vessel's rudder system.
- Check ACU drive output voltage and drive and clutch voltage output (if applicable).
- Check all connections to ACU.
- Check all connections to drive unit.
- Check that the drive unit operates and has not stalled.
- Check steering system is secure.

Error: NO RUDDER REFERENCE

Possible causes	Possible solutions
No rudder angle reference sensor is detected, or the rudder angle reference sensor has turned outside its operational range (50 degrees).	If a rudder angle reference sensor is installed, check the wiring. Inspect the unit for possible damage.

Error: STALL DETECTED

Possible causes	Possible solutions
Motor speed dropped too low for given course change or motor stalling. This can be caused by a faulty drive unit or steering fault. Alternatively, the steering hard-over time may be too slow.	<ul style="list-style-type: none">• Check that the drive unit operates and is not stalled.• Check the steering hard-over time.

Error: CLUTCH OVERLOAD

Possible causes	Possible solutions
Serious drive failure; the drive is demanding too much electrical current due to short-circuit or jamming. Failure caused by a faulty drive unit or motor, or wiring short-circuit. Alternatively, a fault in the steering system may be causing the drive unit to lock-up.	Refer to the clutch power output ratings provided in the <i>Installation Instructions</i> for the relevant Evolution-Series components, and ensure that the clutch for the drive unit does not exceed this power output rating.

Error: CURRENT OVERLOAD

Possible causes	Possible solutions
Serious drive failure; the drive is demanding too much electrical current due to short-circuit or jamming. Failure caused by a faulty drive unit or motor, or wiring short-circuit. Alternatively, a fault in the steering system may be causing the drive unit to lock-up.	Check the drive unit.

Error: NO DATA

Possible causes	Possible solutions
<ul style="list-style-type: none">• The autopilot is in Wind Vane mode and has not received wind angle data for a period of at least 32 seconds.• The autopilot is in Track mode and is not receiving navigation data, or the rudder angle sensor is receiving a low-strength signal. This will clear when the signal improves.	Check the connections to the wind transducer, multifunction display / chartplotter, and autopilot control unit (as appropriate).

Error: NO WIND DATA

Possible causes	Possible solutions
The autopilot is in Wind Vane mode and has not received wind angle data for at least 32 seconds.	Check the connections to the wind transducer.

Error: NO SPEED DATA

Possible causes	Possible solutions
The autopilot has not received speed (STW or SOG) data for at least 10 seconds, while in Auto mode.	Check the connections to the speed transducer. Pilot does not require speed data in order to operate. However, it does enhance the overall performance when in Auto mode.

Error: NO COMPASS

Possible causes	Possible solutions
The EV-Series unit is not receiving heading data.	<ul style="list-style-type: none">• Check the connections to the EV-Series unit.• Power cycle the EV-Series unit, by removing and then re-connecting the SeaTalk NG cable.

Error: RATE GYRO FAIL

Possible causes	Possible solutions
The internal rate gyro on the EV-Series unit has developed a fault. This will be evident as a compass issue, and could cause the compass heading to deviate or lock-up.	If the problem persists, contact your local Raymarine service center.

Error: MOTOR POWER SWAPPED

Possible causes	Possible solutions
On the ACU-Series unit, the Motor cables are connected to the Power terminals, and vice versa.	Switch off the power to the unit and reconnect correctly.

Error: NO GPS DATA

Possible causes	Possible solutions
A source of GPS data is not connected to the SeaTalk NG system.	Check connections to the GPS data source.

Error: JOYSTICK FAULT

Possible causes	Possible solutions
A fault has occurred with the joystick. This alarm applies only to autopilot systems that include a joystick controller.	Check the connections to, and operation of, the joystick.

Error: NO IPS (NO DRIVE DETECTED)

Possible causes	Possible solutions
Loss of communications between the EV-Series unit and drive interface unit.	Check all physical data connections between these devices, as appropriate.

Error: PILOT RESET NORMAL (UNEXPECTED HARDWARE RESET)

Possible causes	Possible solutions
Autopilot resets due to an external event (such as the use of the sleep switch, or faulty wiring causing the autopilot components to power cycle).	Check all system wiring, especially power-related wiring.

Error: PILOT RESET EXCEPTION (UNEXPECTED SOFTWARE RESET)

Possible causes	Possible solutions
The EV-Series unit software has detected a fault that it cannot recover from, and has reset the pilot.	Wait approximately one minute for the EV-Series unit to reset and re-initialize.

14.4 Miscellaneous troubleshooting

Miscellaneous problems and their possible causes and solutions are described here.

EV-Series sensor LED indicator is not working:

Possible causes	Possible solutions
The <i>[Always off]</i> multifunction display / chartplotter setting has been enabled.	<ol style="list-style-type: none">1. On your compatible Raymarine multifunction display / chartplotter (running LightHouse 4 v4.6.42, or later):<ol style="list-style-type: none">a. Open the <i>[Network]</i> settings menu: <i>[Homescreen > Settings > Network]</i>.b. Select the relevant sensor from the network list.c. Select <i>[LEDs:]</i>.d. Select <i>[Normal]</i>.

14.5 Alarms

Alarms are raised by the autopilot system to alert you to mechanical and electrical conditions requiring your attention.

The Evolution-Series components transmit alarm alerts on the SeaTalk NG network for display on autopilot controllers and MFDs, along with an audible alert. The Evolution-Series components stop raising an alarm when the alarm condition ceases or the alarm is acknowledged on the autopilot controller or MFD. If the alarm is safety-critical it will be raised again after a timed delay. Unless otherwise stated in the table below, you should respond to alarms by selecting *[OK]* or *[Acknowledge]* on your autopilot controller or MFD.

Alarm: OFF COURSE

Possible causes	Possible solutions
Autopilot has deviated from planned course.	Check your vessel position and if necessary take manual control to steer the vessel back on course.

Alarm: WIND SHIFT

Possible causes	Possible solutions
Autopilot is unable to maintain navigation to the current wind angle.	Check environmental conditions; consider changing to a different course or target wind angle.

Alarm: LOW BATTERY

Possible causes	Possible solutions
Power supply voltage has dropped below acceptable limits. Caused by low battery voltage or voltage drop due to poor connections or inadequate wiring.	Acknowledge the alarm and then start the engine to recharge the battery. If problem persists, check wiring connections and that the quality and gauge of wiring is adequate for the current draw of the drive unit.

Alarm: LARGE XTE

Possible causes	Possible solutions
Large Cross-Track Error (XTE). The autopilot has deviated more than expected from a planned course.	Check your vessel position and, if necessary, take manual control to steer the vessel back on course.

Alarm: CU DISCONNECTED

Possible causes	Possible solutions
The autopilot Control Unit (CU) / control head has been disconnected.	<ul style="list-style-type: none">• Check the physical cables and connections between the autopilot control head and the SeaTalk NG / DeviceNet system (as applicable). Also between the EV-Series component(s) and the SeaTalk NG / DeviceNet system (as applicable).• If the autopilot control head is connected via a SeaTalk 1 to SeaTalk NG converter, check the converter is using the latest software version.

Alarm: WAYPOINT ADVANCE

Possible causes	Possible solutions
The autopilot has steered the vessel to the current waypoint.	Acknowledge the turn to the next waypoint.

Alarm: ROUTE COMPLETE

Possible causes	Possible solutions
Your vessel has arrived at the end of the current route.	No action required.

Alarm: NO DATA

Possible causes	Possible solutions
<ul style="list-style-type: none">• The autopilot is in Wind Vane mode and has not received wind angle data for at least 32 seconds.• The autopilot is in Track mode and is not receiving navigation data, or the rudder angle sensor is receiving a low-strength signal. This will clear when the signal improves.	Check the connections to the wind transducer, multifunction display / chartplotter, and autopilot control head (as appropriate).

Alarm: PILOT STARTUP

Possible causes	Possible solutions
Autopilot components are initializing.	Some components may take a moment to start up.

CHAPTER 15: OPERATION

CHAPTER CONTENTS

- 15.1 Evolution-Series autopilot operation instructions — page 69

15.1 Evolution-Series autopilot operation instructions

For detailed instructions on how to operate your autopilot system, please refer to the documentation for your autopilot control unit (e.g. p70s / p70Rs pilot control head, or a LightHouse multifunction display / chartplotter).

CHAPTER 16: MAINTENANCE

CHAPTER CONTENTS

- 16.1 Service and maintenance — page 71
- 16.2 Routine equipment checks — page 71
- 16.3 Product cleaning — page 71

16.1 Service and maintenance

This product contains no user serviceable components. Please refer all maintenance and repair to authorized Raymarine dealers. Unauthorized repair may affect your warranty.

16.2 Routine equipment checks

It is recommended that you perform the following routine checks, on a regular basis, to ensure the correct and reliable operation of your equipment:

- Examine all cables for signs of damage or wear and tear.
- Check that all cables are securely connected.

16.3 Product cleaning

Best cleaning practices.

When cleaning products:

- Switch off power supply.
- Use a clean damp cloth to wipe clean.
- Do NOT use: abrasive, acidic, ammonia, solvent or other chemical-based cleaning products.
- Do NOT use a jet wash.

CHAPTER 17: TECHNICAL SUPPORT

CHAPTER CONTENTS

- 17.1 Raymarine technical support and servicing — page 73
- 17.2 Learning resources — page 74

17.1 Raymarine technical support and servicing

Raymarine provides a comprehensive product support service, as well as warranty, service, and repairs. You can access these services through the Raymarine website, telephone, and e-mail.

Product information

If you need to request service or support, please have the following information to hand:

- Product name.
- Product identity.
- Serial number.
- Software application version.
- System diagrams.

Servicing and warranty

Raymarine offers dedicated service departments for warranty, service, and repairs.

Visit the Raymarine website to **read the latest warranty policy**, and **register** your product's warranty online:

- www.bit.ly/rym-warranty

United Kingdom (UK), EMEA, and Asia Pacific:

- Web: www.bit.ly/rym-service
- Tel: +44 (0)1329 246 932

United States (US):

- Web: www.bit.ly/rym-service
- Tel: +1 (603) 324 7900

Web support

Please visit the “Support” area of the Raymarine website for:

- **Manuals and Documents** — www.bit.ly/rym-docs
- **Technical support forum** — www.bit.ly/rym-support
- **Software updates** — www.bit.ly/rym-software

Technical support

Telephone and online support

Region	Contact details
All regions	Online support: www.bit.ly/rym-support
United Kingdom (UK) and EMEA	Telephone: +44 (0)1329 246 777 Address: Marine House, Cartwright Drive, Fareham, PO15 5RJ, UK.
United States (US)	Telephone: Tel: +1 (603) 324 7900 (Toll-free: +800 539 5539) Address: 110 Lowell Road, Hudson, NH 03051, USA.
Australia and New Zealand (Raymarine subsidiary)	Telephone: +61 2 8977 0300 Address: Suite 1.01, 26 Rodborough Road, Frenchs Forest, NSW, 2086, Australia.
France (Raymarine subsidiary)	Telephone: +33 (0)1 46 49 72 30 Address: 35 avenue Michel Crépeau, 17000 La Rochelle - France.
Germany (Raymarine subsidiary)	Telephone: +49 40 237 808 0 Address: Atlantic-Haus, Zirkusweg 1, 20359 Hamburg.
Italy (Raymarine subsidiary)	Telephone: +39 02 9945 1001 Address: Via L. Manara 2, 20812 Limbiate (MB), Italy.
Spain (Authorized Raymarine distributor)	Telephone: +34 96 2965 102 Email: sat@azimut.es
Netherlands / Benelux (Authorized Raymarine distributor)	Telephone: +31 (0)26 3614 905 Address: Florijnweg 21G, 6883 JN VELD, Nederland.

Region	Contact details
Sweden (Raymarine subsidiary)	Telephone: +46 (0)317 633 670 Address: Bolshedens Industriväg 18, 427 50 Billdal, Sweden.
Finland (Raymarine subsidiary)	Telephone: +358 (0)207 619 937 Address: Suomalaistentie 1-3, 02270 Espoo, Finland.
Norway (Raymarine subsidiary)	Telephone: +47 692 64 600 Address: Årvollskogen 30, 1529 Moss, Norway.
Denmark (Raymarine subsidiary)	Telephone: +45 437 164 64 Address: Centervej 7, 4600 Køge, Denmark.
Russia (Distributor)	Telephone: Tel: +7 495 788 0508 Email: info@mikstmarine.ru

Viewing product information

With your MFD Homescreen displayed:

1. Select *[Set-up]*.
2. Select *[Maintenance]*.
3. Select *[Diagnostics]*.
4. Select *[Select Device]*.
5. Select the relevant product from the list.

The Diagnostics page is displayed.

17.2 Learning resources

Raymarine has produced a range of learning resources to help you get the most out of your products.

Video tutorials

Raymarine official channel on YouTube

- <http://www.youtube.com/user/RaymarineInc>

Training courses

Raymarine regularly runs a range of in-depth training courses to help you make the most of your products. Visit the Training section of the Raymarine website for more information:

- www.bit.ly/rym-training

Technical support forum

You can use the Technical support forum to ask a technical question about a Raymarine product or to find out how other customers are using their Raymarine equipment. The resource is regularly updated with contributions from Raymarine customers and staff:

- www.bit.ly/rym-support

CHAPTER 18: TECHNICAL SPECIFICATION

CHAPTER CONTENTS

- 18.1 Physical specification — page 76
- 18.2 Power specification — page 76
- 18.3 Network specification — page 76
- 18.4 Sensor specification — page 76
- 18.5 Environmental specification — page 76
- 18.6 Conformance specification — page 76

18.1 Physical specification

Specification	
Diameter:	140 mm (5.5 in).
Depth (including mounting enclosure):	35 mm (1.4 in).
Depth (including wall bracket):	95 mm (3.8 in).
Weight:	0.29 kg (0.64 lbs)

18.2 Power specification

Specification	
Nominal supply voltage:	12 V (powered by SeaTalk NG system).
Operating voltage range:	10.8 V to 15.6 V dc.
Power consumption (taken from SeaTalk NG system):	30 mA.
SeaTalk NG LEN (Load Equivalency Number):	1

18.3 Network specification

Specification	
Data connections:	<ul style="list-style-type: none">• SeaTalk NG• DeviceNet⁽¹⁾

Important:
(1) The DeviceNet connection is not currently supported.

18.4 Sensor specification

Specification	
Sensors:	<ul style="list-style-type: none">• 3-axis digital accelerometer.• 3-axis digital compass.• 3-axis gyro digital angular rate sensor.

18.5 Environmental specification

Specification	
Operating temperature:	-25 °C to +55 °C (-13 °F to +131 °F).
Storage temperature:	-30 °C to +70 °C (-22°F to +158°F).
Relative humidity:	max 93%.
Waterproof rating:	IPx6.

18.6 Conformance specification

Specification	
EMC compliance:	<ul style="list-style-type: none">• Europe: 2004/108/EC.• Australia and New Zealand: C-Tick, Compliance Level 2.

CHAPTER 19: SPARES AND ACCESSORIES

CHAPTER CONTENTS

- 19.1 Spares — page 78
- 19.2 Accessories — page 78
- 19.3 SeaTalk NG cables and accessories — page 79

19.1 Spares

The following spares are available for your product:

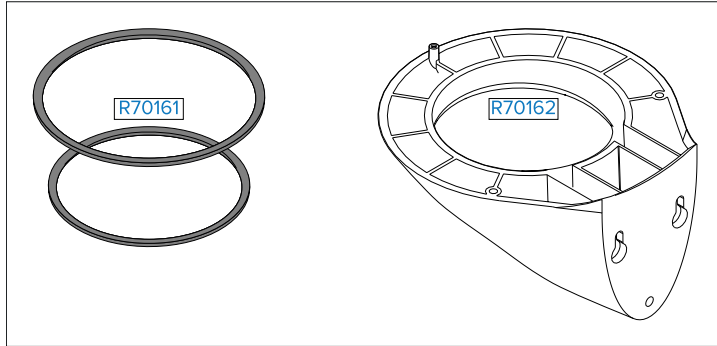

Part	Description
R70161	EV-1 / EV-2 Sealing ring pack.
R70162	EV-1 / EV-2 Wall bracket.

19.2 Accessories

The following accessories are available for your product:

Note:

For pilot controller and drive interface unit spares and accessories, refer to the *Installation Instruction* documentation specific to those products.

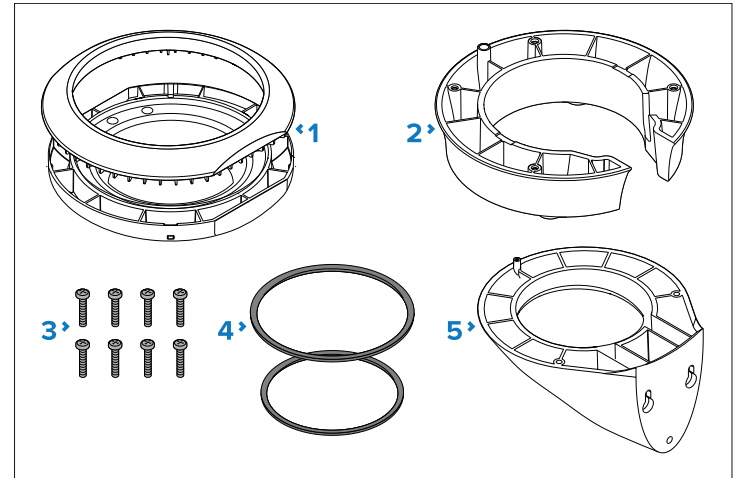

Part	Description
A80437	Deck mounting kit, consisting of: <ol style="list-style-type: none"> 1. Mounting adaptor (clamshell). 2. Riser. 3. Fixings. 4. Sealing rings. 5. Wall bracket.

19.3 SeaTalk NG cables and accessories

SeaTalk NG cables and accessories for use with compatible products.

SeaTalk NG kits

SeaTalk NG kits enable you to create a simple SeaTalk NG backbone.

Starter kit (part number: T70134) consists of:

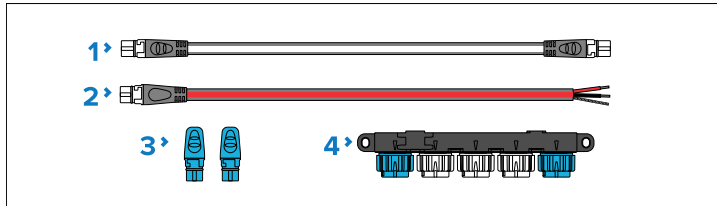

- 1 x Spur cable 3 m (9.8 ft) (part number: **A06040**). Used to connect device to the SeaTalk NG backbone.
- 1 x Power cable 2 m (6.6 ft) (part number: **A06049**). Used to provide 12 V dc power to the SeaTalk NG backbone.
- 2 x Backbone terminators (part number: **A06031**). Terminators must be fitted to both ends of the SeaTalk NG backbone.
- 1 x 5-Way connector (part number: **A06064**). Each connector block allows connection of up to 3 SeaTalk NG devices. Multiple connector blocks can be 'daisy chained' together.

Backbone kit (part number: A25062) consists of:

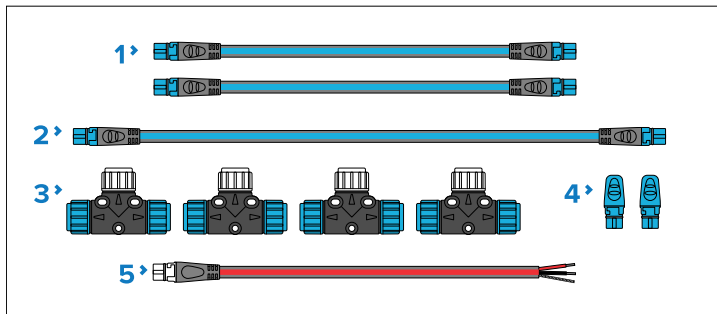

- 2 x Backbone cables 5 m (16.4 ft) (part number: **A06036**). Used to create and extend the SeaTalk NG backbone.

- 1 x Backbone cable 20 m (65.6 ft) (part number: **A06037**). Used to create and extend the SeaTalk NG backbone.
- 4 x T-piece (part number: **A06028**). Each T-piece allows connection of one SeaTalk NG device. Multiple T-pieces can be 'daisy chained' together.
- 2 x Backbone terminators (part number: **A06031**). Terminators must be fitted to both ends of the SeaTalk NG backbone.
- 1 x Power cable 2 m (6.6 ft) (part number: **A06049**). Used to provide 12 V dc power to the SeaTalk NG backbone.

Evolution-Series autopilot cable kit (part number: R70160) consists of:

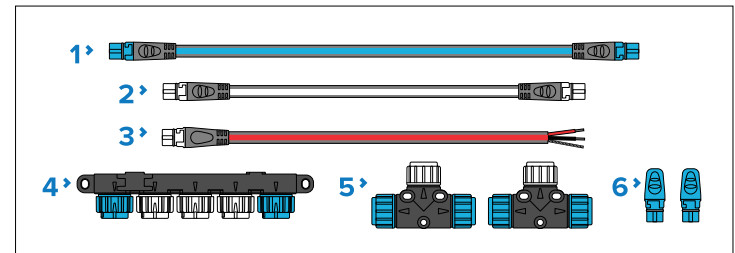

- 1 x Backbone cable 5 m (16.4 ft) (part number: **A06036**). Used to create and extend the SeaTalk NG backbone.
- 1 x Spur cable 1 m (3.3 ft) (part number: **A06040**). Used to connect device to the SeaTalk NG backbone.
- 1 x Power cable 2 m (6.6 ft) (part number: **A06049**). Used to provide 12 V dc power to the SeaTalk NG backbone.
- 1 x 5-Way connector (part number: **A06064**). Each connector block allows connection of up to 3 SeaTalk NG devices. Multiple connector blocks can be 'daisy chained' together.
- 2 x T-pieces (part number: **A06028**). Each T-piece allows connection of one SeaTalk NG device. Multiple T-pieces can be 'daisy chained' together.
- 2 x Backbone terminators (part number: **A06031**). Terminators must be fitted to both ends of the SeaTalk NG backbone.

SeaTalk 1 to SeaTalk NG converter kit (part number: E22158) consists of:

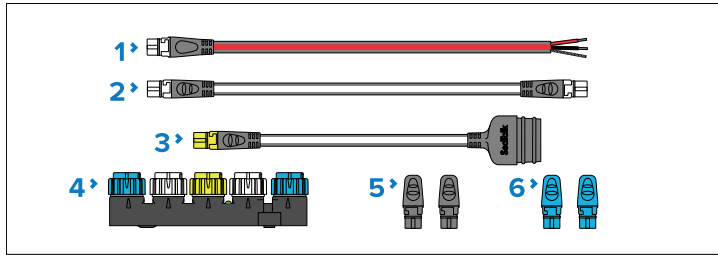

- 1 x Power cable 2 m (6.6 ft) (part number: **A06049**). Used to provide 12 V dc power to the SeaTalk NG backbone.
- 1 x Spur cable 1 m (3.3 ft) (part number: **A06039**). Used to connect a device to the SeaTalk NG backbone.
- 1 x SeaTalk 1 (3 pin) to SeaTalk NG adapter cable 0.4 m (1.3 ft) (part number: **A22164**). Used to connect SeaTalk 1 devices to the SeaTalk NG backbone via the SeaTalk 1 to SeaTalk NG converter.
- 1 x SeaTalk 1 to SeaTalk NG converter (part number: **E22158**). Each converter allows connection of one SeaTalk 1 device and up to 2 SeaTalk NG devices.
- 2 x Spur blanking plugs (part number: **A06032**). Used to cover unused spur connections in 5-way blocks, T-piece connectors and SeaTalk 1 to SeaTalk NG converter.
- 2 x Backbone terminators (part number: **A06031**). Terminators must be fitted to both ends of the SeaTalk NG backbone.

NMEA 0183 VHF 2-wire to SeaTalk NG converter kit (part number: E70196) consists of:

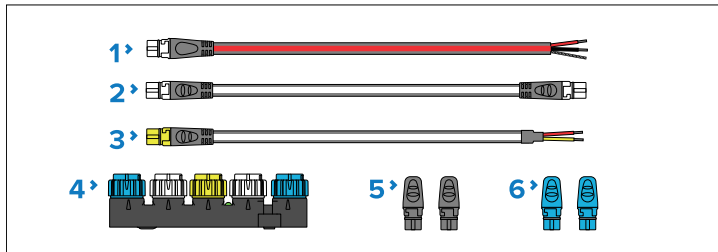

- 1 x Power cable 2 m (6.6 ft) (part number: **A06049**). Used to provide 12 V dc power to the SeaTalk NG backbone.
- 1 x Spur cable 1 m (3.3 ft) (part number: **A06039**). Used to connect a device to the SeaTalk NG backbone.

- 1 x NMEA 0183 VHF stripped-end (2-wire) to SeaTalk NG adapter cable 1 m (3.3 ft) (part number: **A06071**). Used to connect an NMEA 0183 VHF radio to the SeaTalk NG backbone via the NMEA 0183 to SeaTalk NG converter.
- 1 x SeaTalk 1 to SeaTalk NG converter (part number: **E22158**). Each converter allows connection of one SeaTalk 1 device and up to 2 SeaTalk NG devices.
- 2 x Spur blanking plugs (part number: **A06032**). Used to cover unused spur connections in 5-way blocks, T-piece connectors, and the SeaTalk 1 to SeaTalk NG converter.
- 2 x Backbone terminators (part number: **A06031**). Terminators must be fitted to both ends of the SeaTalk NG backbone.

SeaTalk NG spur cables

SeaTalk NG spur cables are required to connect devices to the SeaTalk NG backbone.

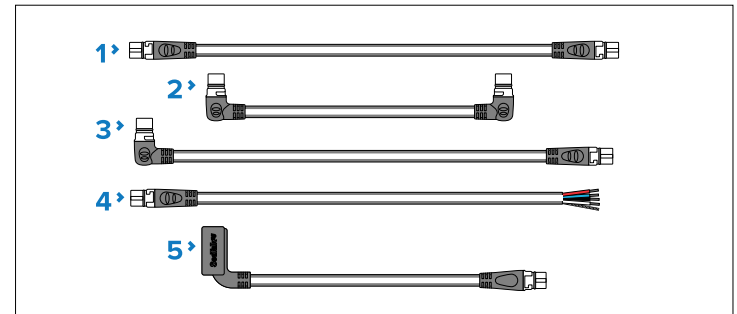

- SeaTalk NG spur cables:
 - Spur cable 0.4 m (1.3 ft) (part number: **A06038**).
 - Spur cable 1 m (3.3 ft) (part number: **A06039**).
 - Spur cable 3 m (9.8 ft) (part number: **A06040**).
 - Spur cable 5 m (16.4 ft) (part number: **A06041**).
- Elbow (right-angled) to elbow (right-angled) spur cable 0.4 m (1.3 ft) (part number: **A06042**). Used in confined spaces where a straight spur cable will not fit.
- Elbow (right-angled) to straight spur cable 1 m (3.3 ft) (part number: **A06081**). Used in confined spaces where a straight spur cable will not fit.

- SeaTalk NG to stripped-end spur cables (connects compatible products that do not have a SeaTalk NG connector, such as transducer pods):
 - SeaTalk NG to stripped-end spur cable 1 m (3.3 ft) (part number: **A06043**)
 - SeaTalk NG to stripped-end spur cable 3 m (9.8 ft) (part number: **A06044**)
- ACU-Series / SPX-Series autopilot to SeaTalk NG spur cable 0.3 m (1.0 ft) (part number **R12112**). Connects the course computer to the SeaTalk NG backbone. This connection can also be used to provide 12 V dc power to the SeaTalk NG backbone.

SeaTalk NG backbone cables

SeaTalk NG backbone cables are used to create or extend a SeaTalk NG backbone.

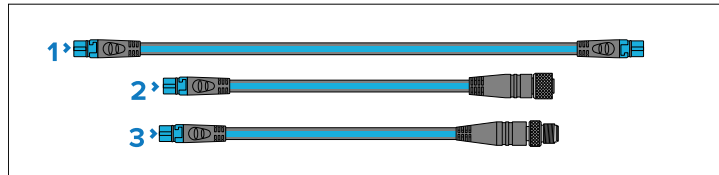

- Backbone cables:
 - Backbone cable 0.4 m (1.3 ft) (part number: **A06033**).
 - Backbone cable 1 m (3.3 ft) (part number: **A06034**).
 - Backbone cable 3 m (9.8 ft) (part number: **A06035**).
 - Backbone cable 5 m (16.4 ft) (part number: **A06036**).
 - Backbone cable 9 m (29.5 ft) (part number: **A06068**).
 - Backbone cable 20 m (65.6 ft) (part number: **A06037**).
- SeaTalk NG to DeviceNet (female) Backbone cable 0.4 m (1.3 ft) (part number: **A80675**)
- SeaTalk NG to DeviceNet (male) Backbone cable 0.4 m (1.3 ft) (part number: **A80674**)

SeaTalk NG power cables

SeaTalk NG power cables are used to provide the SeaTalk NG backbone with a single 12 V dc power source. The power connection must include a 5 amp inline fuse (not supplied).

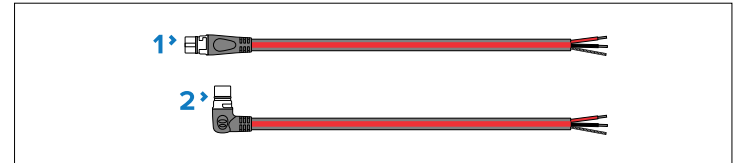

- Power cable (straight) 2 m (6.6 ft) (part number: **A06049**).
- Elbow (right-angled) power cable 2 m (6.6 ft) (part number: **A06070**).

SeaTalk NG connectors

SeaTalk NG connectors are used to connect SeaTalk NG devices to the SeaTalk NG backbone and to create and extend the backbone.

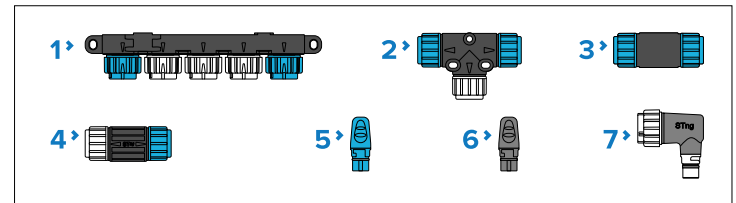

- 5-Way connector (part number: **A06064**). Each connector block allows connection of up to 3 SeaTalk NG devices. Multiple connector blocks can be 'daisy chained' together.
- T-piece (part number: **A06028**). Each T-piece allows connection of one SeaTalk NG device. Multiple T-pieces can be 'daisy chained' together.
- Backbone extender (part number: **A06030**). Used to connect 2 backbone cables together.
- Inline terminator (part number: **A80001**). Used to connect a spur cable and SeaTalk NG device at the end of a backbone instead of a backbone terminator.
- Backbone terminator (part number: **A06031**). Terminators must be fitted to both ends of the SeaTalk NG backbone.
- Spur blanking plug (part number: **A06032**). Used to cover unused spur connections in 5-Way blocks, T-piece connectors, or the SeaTalk 1 to SeaTalk NG converter.
- Elbow (right-angled) spur connector (part number: **A06077**). Used in confined spaces where a straight spur cable will not fit.

SeaTalk NG adaptors and adaptor cables

SeaTalk NG adaptor cables are used to connect devices designed for different CAN Bus backbones (e.g.: SeaTalk 1 or DeviceNet) to the SeaTalk NG backbone.

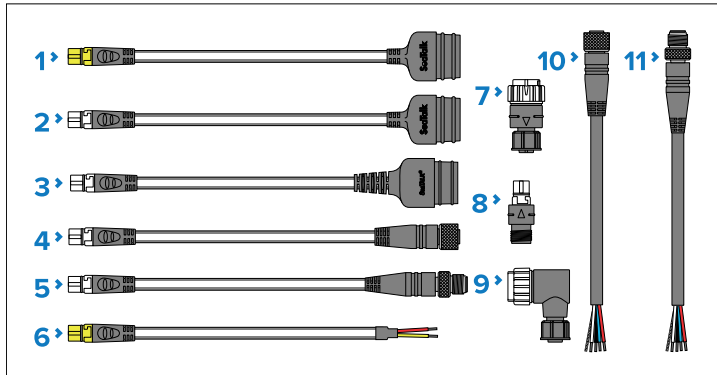

1. SeaTalk 1 (3 pin) to SeaTalk NG converter cable 1 m (3.3 ft) (part number: **A22164 / A06073**). Can be used to connect a SeaTalk 1 device to a SeaTalk NG backbone via the SeaTalk 1 to SeaTalk NG converter, or to connect a SeaTalk NG product directly to a SeaTalk 1 network.
2. SeaTalk 1 (3 pin) to SeaTalk NG adaptor cable 0.4 m (1.3 ft) (part number: **A06047**). Can be used to connect a SeaTalk 1 device to a SeaTalk NG backbone via the SeaTalk 1 to SeaTalk NG converter, or to connect a SeaTalk NG product directly to a SeaTalk 1 network.
3. SeaTalk 2 (5 pin) to SeaTalk NG adaptor cable 0.4 m (1.3 ft) (part number: **A06048**). Used to connect SeaTalk 2 devices or networks to a SeaTalk NG backbone.
4. SeaTalk NG to DeviceNet (female) adaptor cables connect NMEA 2000 devices that use a DeviceNet connector to the SeaTalk NG backbone, or connects SeaTalk NG devices to an NMEA 2000 network. The following cables are available:
 - SeaTalk NG to DeviceNet (female) adaptor cable 0.4 m (1.3 ft) (part number: **A06045**).
 - SeaTalk NG to DeviceNet (female) adaptor cable 1 m (3.3 ft) (part number: **A06075**).
5. SeaTalk NG to DeviceNet (male) adaptor cables. Connect NMEA 2000 devices that use a DeviceNet connector to the SeaTalk NG backbone, or connect SeaTalk NG devices to an NMEA 2000 network. The following cables are available:
 - SeaTalk NG to DeviceNet (male) adaptor cable 0.1 m (0.33 ft) (part number: **A06078**).
 - SeaTalk NG to DeviceNet (male) adaptor cable 0.4 m (1.3 ft) (part number: **A06074**).
 - SeaTalk NG to DeviceNet (male) adaptor cable 1 m (3.3 ft) (part number: **A06076**).
 - SeaTalk NG to DeviceNet (male) adaptor cable 1.5 m (4.92 ft) (part number: **A06046**).
6. NMEA 0183 stripped-end (2-wire) to SeaTalk NG adapter cable 1 m (3.3 ft) (part number: **A06071**). Used to connect an NMEA 0183 VHF radio to the SeaTalk NG backbone via the NMEA 0183 to SeaTalk NG converter.
7. SeaTalk NG (male) to DeviceNet (female) adaptor (**A06082***).
8. SeaTalk NG (female) to DeviceNet (male) adaptor (**A06083***).
9. SeaTalk NG (male) to DeviceNet (female) elbow (right-angled) adaptor (**A06084***).
10. DeviceNet (female) to stripped-end adaptor cable (0.4 m (1.3 ft)) (part number: **E05026**).
11. DeviceNet (male) to stripped-end adaptor cable (0.4 m (1.3 ft)) (part number: **E05027**).

Important:

* Do NOT connect the A06082, A06083, or A06084 adaptors directly to a backbone. Only connect as part of a **spur** connection between backbone and device.

Appendix A NMEA 2000 PGNs

Your product supports the following NMEA 2000 PGNs.

Administration PGNs

- **59392** — ISO Acknowledge (Transmit)
- **59904** — ISO Request (Receive / Transmit)
- **60928** — ISO Address Claim (Receive / Transmit)
- **65240** — ISO Commanded address (Receive)
- **126208** — Request group function (Receive / Transmit)
- **126208** — Command group function (Receive / Transmit)
- **126208** — Acknowledge group function (Receive / Transmit)
- **126464** — PGN List (Receive / Transmit)
- **126996** — Product information (Transmit):
 - NMEA 2000 Database Version
 - NMEA® Manufacturer's Product Code
 - NMEA® Manufacturer's Model ID
 - Manufacturer's Software Version Code
 - Manufacturer's Model Version
 - Manufacturer's Model Serial Code
 - NMEA 2000 Certification Level
 - Load Equivalency

Raymarine provides field programmability of the Device and System Instances within PGN 60928 which can be commanded via use of PGN 126208, as required by the latest NMEA 2000 standard.

Data PGNs

- **127245** — Rudder angle (Receive / Transmit)
- **127250** — Vessel heading (Receive / Transmit)
- **127258** — Magnetic Variation (Receive)
- **128259** — Speed Through Water (STW) (Referenced) (Receive)

- **129026** — Course Over Ground (COG) and Speed Over Ground (SOG) rapid update (Receive)
- **129029** — GNSS position data (Receive):
 - Date
 - Time
 - Latitude
 - Longitude
- **129283** — Cross Track Error (Receive)
- **129284** — Navigation data (for following routes) (Receive):
 - Active Leg Distance To Waypoint (DTW)
 - Course / Bearing reference
 - Perpendicular Crossed
 - Arrival Circle Entered
 - Calculation Type
 - Estimated Time of Arrival (ETA)
 - Estimated Date of Arrival
 - Active Leg Bearing Origin to Destination (BOD)
 - Active Leg Bearing To Waypoint (BTW)
 - Active Leg Origin Waypoint ID
 - Active Waypoint ID
 - Destination Waypoint Latitude
 - Destination Waypoint Longitude
 - Waypoint closing velocity
- **129285** — Active Waypoint data (Receive)
- **130306** — Wind data (Receive)

Appendix B EV-1 software release history

The list below is a cumulative list of the general improvements introduced in subsequent releases of the EV-1 software, since the initial release (**v1.00**) (2013). Software releases include any combination of new features, performance improvements, and bug fixes.

EV-1 software download link

www.bit.ly/rym-software

EV-1, v3.17

(Software release date: *February 2024*)

General improvements:

Added support for a new LED indicator 'Switch off' setting which can be toggled via a networked LightHouse 4 multifunction display (running software version v4.6.74 or later). For more information, refer to: [p.62 – Switching off sensor LEDs](#)

Added support for a new LED indicator 'Find me' setting which can be toggled via a networked LightHouse 4 multifunction display (running software version v4.6.74 or later). For more information, refer to: [p.63 – Find me](#)

Added ability to Steer to Target wind angle from polar, using a compatible autopilot controller.

Fixed issues:

No bug fixes in this release.

EV-1, v3.14

(Software release date: *March 2023*)

General improvements:

Added compatibility with Axiom-Series and Axiom 2-Series MFDs / chartplotters running LightHouse 4, v4.4.70 (or later).

Fixed issues:

No bug fixes in this release.

EV-1, v3.13

(Software release date: *December 2022*)

General improvements:

Added compatibility with other Raymarine devices requiring internal component changes (due to component obsolescence).

Fixed issues:

Resolves EV-1 issues related to not detecting arrivals.

Resolved issue when connected to a SeaTalk 1 to SeaTalk NG Converter creating false alarms. To fully resolve this issue, ensure that the SeaTalk 1 to SeaTalk NG Converter is upgraded to the latest software.

EV-1, v3.05

(Software release date: *August 2020*)

General improvements:

Introduces an enhanced vessel "Type 1" profile for larger vessels. This is the "Power Slow Turn" profile, for Displacement / Workboats & Large Cruising Powerboats.

Fixed issues:

No bug fixes in this release.

EV-1, v3.02

(Software release date: *July 2018*)

General improvements:

Improved address claim handling to correct compatibility issues with third-party steering systems, which could cause the alarm 'No Drive Detected' if engine was powered off for a period of time.

Fixed issues:

No bug fixes in this release.

EV-1, v3.01

(Software release date: *June 2018*)

General improvements:

Added compatibility with internal component changes for EV-1 (due to component obsolescence).

Fixed issues:

No bug fixes in this release.

EV-1, v2.18

(Software release date: *May 2017*)

General improvements:

Improves the management of Waypoint numbers from third-party pilot systems.

Fixed issues:

Corrected a "No Navigation" fault error that can occur if entering Track mode from data via multiple third-party pilot systems.

EV-1, v2.17

(Software release date: *May 2016*)

General improvements:

Track Acquisition & Track Keeping enhancements.

Vane mode – Wind steering Performance enhancements.

Auto Tack improvements.

Windshift Alarm improvements – including the ability to switch off.

General improvements:

Enhanced Compass Calibration Routine for EV-Series sensors.

NMEA 2000 improvements.

Note:

- p70-Series products must be running software version v3.05 (or later).
- ACU-Series products must be running software version v2.17 (or later).

Fixed issues:

No bug fixes in this release.

EV-1, v1.11

(Software release date: *September 2014*)

General improvements:

Improved SeaTalk NG bus address claim handling.

Fixed issues:

Corrects an issue with third-party equipment transmitting incomplete navigation data causing Tracking and 'No Pilot' errors.

EV-1, v1.08

(Software release date: *June 2014*)

General improvements:

Further improvements to the Speed data selection algorithm to resolve issues where the incorrect speed is transmitted from some engines.

Supports the selection of “STW”, “SOG” or “Default” from the Pilot Calibration options.

Note:

p70-Series products must be running software version v2.12 (or later).

Factory calibration of Magnetometer alignment improved to enhance heading accuracy.

Fixed issues:

No bug fixes in this release.

EV-1, v1.06

(Software release date: *April 2014*)

General improvements:

The Pilot now uses the highest value of bus speed from SOG or STW; this eliminates the pilot instability issues seen on some vessels that have a faulty or STW paddle wheel Transducer which has not been inserted.

For vessels that don't have SOG or STW data sources, Cruising Speed is now selectable in Pilot Vessel Settings when Cal Lock is switched off.

Fixed issues:

Heading errors caused by vessels undertaking a fast banked turn have now been corrected. This was previously seen as poor overlay performance.

EV-1, v1.00

(Software release date: *2013*)

General improvements:

Initial public release.

Index

A

Accessories.....	78
SeaTalk NG adaptor cables.....	82
SeaTalk NG backbone cables.....	81
SeaTalk NG cables.....	79
SeaTalk NG connectors.....	81
SeaTalk NG kits.....	79
SeaTalk NG Power cables.....	81
SeaTalk NG spur cables.....	80
ACU (Actuator Control Unit).....	15
AHRS (Attitude Heading Reference Sensor).....	15
Alarms.....	66–67
CU Disconnected.....	67
Large XTE.....	66
Low Battery.....	66
No Data.....	67
Off Course.....	66
Pilot Startup.....	67
Route Complete.....	67
Waypoint Advance.....	67
Wind Shift.....	66
Applicable products.....	12
Autopilot control head.....	22
Autopilot control unit.....	22
Autopilot controller.....	22
Autopilot set-up.....	
Deadband angles.....	58
Rudder Damping.....	58–59

B

Backbone length, SeaTalk NG.....	52
Box contents.....	26
Bracket mount.....	36
Bracket release.....	38

C

Cable

Bend radius.....	40
Protection.....	40
Routing.....	40
Security.....	40
Strain relief.....	40
CAN bus.....	15
Cleaning.....	9, 71
Compass safe distance.....	31
Compatible autopilot controllers.....	
SeaTalk 1.....	23
SeaTalk NG.....	22
Compatible displays.....	22
Compatible MFDs / Chartplotters.....	24
Connections.....	
Battery.....	54
Distribution panel.....	54
Network connections.....	
Minimum system example.....	
ACU-100 / ACU-150.....	17, 43
ACU-200 / ACU-400.....	17, 45
Overview.....	43
Recommended system example.....	
ACU-100 / ACU-150.....	18, 44
ACU-200 / ACU-300 / ACU-400.....	19, 46
SeaTalk 1.....	
Pilot controller connection.....	48
SeaTalk NG.....	
Pilot controller connection.....	48
Power.....	50, 52
Power connections.....	
Power distribution.....	53
SeaTalk NG.....	43

D

Data source exceptions.....	16
Data sources.....	16
Deadband angles.....	58
Declaration of Conformity.....	10
Diagnostics.....	61
Disassembly.....	38
Distribution panel connection.....	54

E		
Electromagnetic Compatibility	31	
Electromagnetic interference safe distance	31	
EMC, <i>See</i> Electromagnetic Compatibility		
Error message		
Auto Release	63	
Clutch Overload	64	
Current Overload.....	64	
Drive Stopped.....	63	
Joystick Fault.....	65	
Motor Power Swapped	65	
No Compass.....	65	
No Data.....	64	
No GPS Data	65	
No IPS (No Drive Detected).....	65	
No Rudder Reference	64	
No Speed Data	65	
No Wind Data	64	
Pilot Reset Exception.....	65	
Pilot Reset Normal	65	
Rate Gyro Fail.....	65	
Stall Detected.....	64	
F		
Fuse requirement	50	
I		
Inline fuse	50	
Installation		
Bracket mount	36	
Bracket release.....	38	
Surface mount	34	
Surface mount (with riser).....	35	
Interference.....	31	
<i>See also</i> Compass safe distance		
<i>See also</i> Electromagnetic interference safe distance		
L		
Load equivalency number.....	52	
		Location requirements
		30
M		
Maintenance.....	9, 71	
MFD		
Compatibility	24	
Multiple data source (MDS) exceptions	16	
Multiple data sources (MDS).....	16	
N		
Network connections.....	43	
Network length,		
SeaTalk NG.....	52	
NMEA 2000	83	
LEN	52	
O		
Operation instructions	69	
P		
Parts supplied.....	26	
PGNs	83	
Position sensor		
Find me	63	
Find Me.....	63	
Position sensor LED		
Find Me	62	
Go dark	62	
LEDs off.....	62	
Power		
Battery connection.....	54	
Distribution panel	54	
Fuses.....	50	
Sharing a breaker	54	
Power cable extension.....	52, 55	
Power connection point	52	
Product dimensions.....	28	

Product documentation	
Applicable documentation	12
Related documentation	
ACU Autopilot documentation	12
Autopilot controller documentation	12
SeaTalk NG documentation	12
Product loading	52
Product overview	15
Product recycling (WEEE)	10
Product support	73
Protocols	
SeaTalk NG	15

R

Routine checks	71
Rudder Damping	58–59

S

SeaTalk NG	15, 43, 53
Adaptor cables	82
Backbone cables	81
Connectors	81
Kits	79
LEN	52
Load equivalency number	52
Power	50, 52
Power cables	51, 81
Spur cables	80
System loading	53
SeaTalk NG cables	79
Service Center	73
Servicing	9, 71
Software release history	12, 84
Software updates	20
Software version	12
Spares	78
Support forum	74
Suppression ferrites	9, 41
<i>See also</i> EMC	
Surface mount	34

Surface mount (with riser)	35
System Checks	
Autopilot setup	58
Post-installation	58
System components	
Essential	16
Optional	16
Recommended	16

T

Technical specification	
Conformance specification	76
Environmental specification	76
Network specification	76
Physical specification	76
Power specification	76
Sensor specification	76
Technical support	73–74
Tools required	34
Training courses	74
Troubleshooting	
Alarms	66–67
Diagnostics	61
LED status	62
Error messages	63–65
Miscellaneous troubleshooting	66

U

Upgrading, software	20
---------------------------	----

W

Warranty	10, 73
WEEE Directive	10
What's in the box	26